

Multipurpose & Tug Fenders



PRODUCT BROCHURE

The Smarter Approach



Connect with The Smarter Approach

By Trelleborg Marine and Infrastructure

-  Visit: [TrelleborgMarineandInfrastructure](#)
-  Connect: [trelleborg-marine-and-infrastructure](#)
-  Discover: [TrelleborgMarineandInfrastructure](#)
-  Converse: [@TrelleborgMI](#)
-  Explore: [marineandinfrastructure](#)
-  Discover: [TrelleborgMarineandInfrastructure](#)

The demanding nature of commercial ports and terminals means you need partnership that provides much more than technically superior products and technologies. You need to work with a partner that combines best practice expertise gained through worldwide experience with a deep understanding of local requirements and regulations. At Trelleborg, we call this the Smarter Approach.

Our Smarter Approach combines global reach with feet-on-the-ground local presence, delivering solutions that continually enhance your operations. Smart technologies are at the forefront of improving operational efficiencies. Trelleborg's innovative SmartPort offering deploys the latest in marine technology applications to help ports and terminals optimize their operations.

Connect with a partner that combines smart solutions, proven product capability and industry expertise to maintain and enhance port and vessel performance. Take a Smarter Approach, with Trelleborg Marine and Infrastructure.

Multipurpose & Tug Fenders

Trelleborg Marine and Infrastructure is a world leader in the design and manufacture of advanced marine fender systems.

We provide bespoke solutions for large and complex projects all over the world. Best practice design and quality materials ensure a long, low maintenance service life, no matter how demanding the working and environmental conditions.

All fenders are supplied fully tested and meet PIANC 2002 guidelines. Our pneumatic fenders are also completely ISO17357-1:2014 compliant. Our high performance solutions combine low reaction force and hull pressure with good angular performance and rugged construction.

Trelleborg's fender systems can be integrated with SmartPort. SmartPort by Trelleborg is a technology platform that connects disparate, data-driven assets, giving stakeholders a holistic view of operations to power communication and decision making.

Take a Smarter Approach to fender performance with Trelleborg.

Contents

MULTIPURPOSE & TUG FENDERS

A Smarter Approach at every stage	3
High Performance Super Abrasion Resistant Fenders	5
Cylindrical Fenders	7
Extrusions	11
Composite Fenders	15
Heavy Duty Molded Fenders	17
Fender Bars	19
Marine Protection Plates	21
Ramp and Cope Protections	23
Shear Fenders	25
Tug Fenders	27
Tug Cylindricals	29
M-Fenders	31
W-Fenders	33
Keyhole Fenders	35
Accessories	37

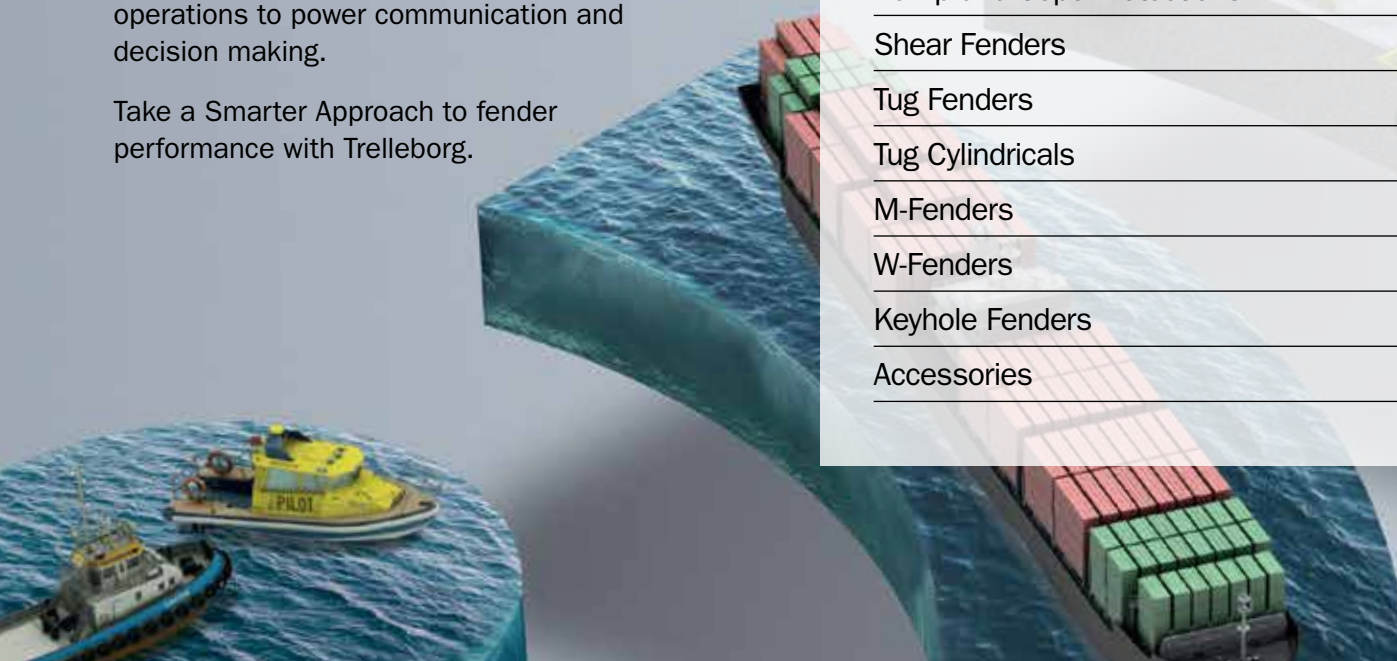

A Smarter Approach at every stage

A smarter approach to...

CONSULTATION

Consultation from the earliest project phase to ensure the optimum fender systems and marine technology solutions are specified, with full technical support from our global offices.



CONCEPT

Conceptual design in your local office – with full knowledge of local standards and regulations, delivered in your language – for optimized port and vessel solutions.



DESIGN

Concepts are taken to our Engineering Centers of Excellence in India where our team generates 3D CAD designs, application-engineering drawings, a bill of materials, finite engineering analyses and calculations for both our fender systems and marine technology solutions.



MANUFACTURE

Our entire product range is manufactured in-house, meaning we have full control over the design and quality of everything we produce. Our strategically located, state-of-the-art facilities ensure our global, industry leading manufacturing capability.



TESTING

Across our entire product range, stringent testing comes as standard at every step in our in-house manufacturing process. We ensure that lifecycle and performance of our entire product range meets your specifications, and more.



INSTALLATION

Dedicated project management, from solution design right the way through to on-site installation support. We design products and solutions that always consider ease of installation and future maintenance requirements.



SUPPORT

Local support on a truly global scale, with customer support teams all over the world. And this service doesn't stop after a product is installed. You have our full support throughout the entire lifetime of your project, including customized training programs, maintenance and onsite service and support.



THE FUTURE

Deploying the latest in smart technologies to enable fully automated, data-driven decision making that optimizes port and terminal efficiency. At Trelleborg, we're constantly evolving to provide the digital infrastructure our industry increasingly needs.



When you choose Trelleborg you ensure your expectations will be met, because we deliver a truly end-to-end service – retaining vigilance and full control at every stage.

High Performance Super Abrasion Resistant Fenders



Trelleborg has developed a superior new rubber compound used in the high performance super abrasion resistant (HPSAR) cylindrical & tug cylindrical fenders.

This superior compound could increase the fenders' service life by up to five times, reducing maintenance and replacement costs.

FEATURES

- Lower density fenders, less weight
- Potential savings on running costs
- High abrasion resistance
- Longer service life and less damage
- Superior physical properties

APPLICATIONS

- Bulk cargo berths
- General cargo quays
- RoRo and ferry terminals
- Fishing and workboat berths
- Pontoons and floating structures
- All types of tugs

High Performance Super Abrasion Resistant Fenders

This new compound not only increases service life, but has a lower density than traditional solutions, which means less weight and potential savings. The new compound offers enormously

improved characteristics such as elongation at break and tear strength, and the abrasion resistance critical for tug applications, as shown in the table below.

RUBBER PROPERTIES OF HPSAR VS TRADITIONAL COMPOUND

PROPERTY	TESTING STANDARD	CONDITION	REQUIREMENT	
			HPSAR	TRADITIONAL COMPOUND
Tensile Strength	ISO 37; ASTM D412 Die C; BS ISO 37; DIN 53504; AS 1683.11; JIS K 6251	Original	16.0 Mpa (min)	13.0 Mpa (min)
		Aged for 96 hours at 70°C	14.4 Mpa (min)	10.4 Mpa (min)
Elongation at Break	ISO 37; ASTM D412 Die C; BS ISO 37; DIN 53504; AS 1683.11; JIS K 6251	Original	350% (min)	280 % (min)
		Aged for 96 hours at 70°C	280% (min)	224% (min)
Tear Strength	ISO 34-1; ASTM D624 Die B; AS 1683.12; JIS K 6252-1	Original	70 kN/m (min)	60 kN/m (min)
Abrasion Resistance*	BS 903 A9 Method B	3000 revolution	0.5 cc (max)	1.5 cc (max)

*Lower is better

Tug fenders using the HPSAR compound should be specified by more than traditional parameters such as abrasion resistance, tensile strength, tear resistance and elongation at break. To ensure the quality and performance of the fenders, the superior compound requirements should be specified, as shown in the table below.

Contrary to traditional compound, the HPSAR compound specifications should include standards for density, polymer percentage, carbon black percentage, ash percentage and polymer to filler ratio. Rubber compound composition should be evaluated upon receipt of the final product, to ensure that the fenders will perform in harsh conditions over a long service life.

CHEMICAL COMPOSITION

TEST	STANDARD	SPECIFICATION
Density	ISO 2781	Max 1.18 g/cc
Polymer %	ASTM D6370	Min 45%
Carbon Black %	ASTM D6370	Min 20%
Ash %	ASTM D297	Max 5%
Rubber to filler ratio	-	> 1.2

Note: Please refer to pg 8 for the performance table of the HPSAR fenders.

Cylindrical Fenders



Cylindrical fenders have protected ships for more years than any other fender type. They are simple, versatile and easy to install.

Their progressive reaction makes them ideal for berths serving large and small vessels. The wide range of available sizes (as well as almost any intermediate size) means cylindrical fenders can be closely matched to each application.

FEATURES

- Simple and economical design
- Easy to install and maintain
- All sizes up to 2700 mm diameter
- Thick wall resists abrasion and wear
- Progressive load-deflection curve

APPLICATIONS

- Bulk cargo berths
- General cargo quays
- RoRo and ferry terminals
- Fishing and workboat berths
- Pontoons and floating structures
- Tug havens

Note: HPSAR cylindrical fenders are available. Please refer to pg 5 - 6.

Cylindrical Fenders

PERFORMANCE (RPD)

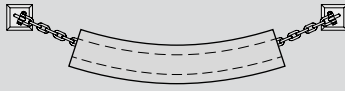
OD × ID (mm)	OD / ID	E (kNm)	R (kN)	P* (kN/m ²)	WEIGHT (kg/m)	TYPICAL FIXING ARRANGEMENTS
100 × 50	2.00	0.8	43	547	7.2	
125 × 65	1.92	1.3	51	500	11.0	
150 × 75	2.00	1.8	65	552	16.3	
175 × 75	2.33	2.7	92	781	24.1	
200 × 100	2.00	3.3	86	547	29.0	
250 × 125	2.00	5.1	108	550	45.3	
300 × 150	2.00	7.4	129	547	65.2	
380 × 190	2.00	11.8	164	550	105	
400 × 200	2.00	13.1	172	547	116	
450 × 225	2.00	16.6	194	549	147	
500 × 250	2.00	28	275	700	181	
600 × 300	2.00	40	330	700	255	
800 × 400	2.00	72	440	700	453	
1000 × 500	2.00	112	550	700	707	
1200 × 600	2.00	162	660	700	1018	
1400 × 700	2.00	220	770	700	1386	
1400 × 800	1.75	208	649	516	1245	
1500 × 750	2.00	253	825	700	1591	
1600 × 800	2.00	288	880	700	1810	
1750 × 900	1.94	340	929	657	2124	
2000 × 1200	1.67	415	871	462	2414	
2400 × 1200	2.00	647	1321	701	4073	
2700 × 1300	2.08	818	1486	728	5154	

*Excludes effect of fixing accessories. Deflection = ID. Performance per meter length.

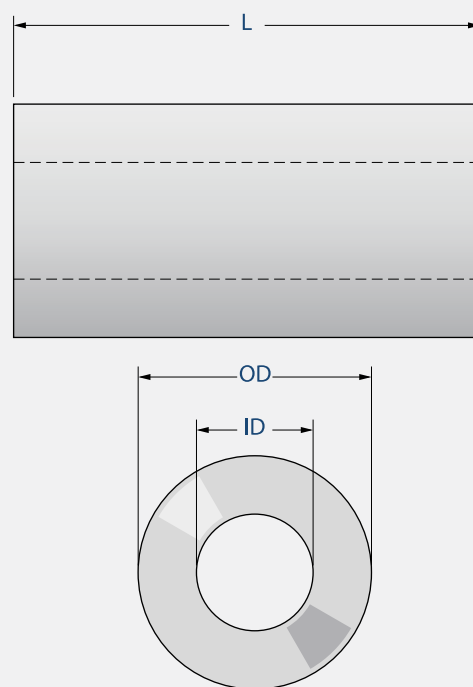
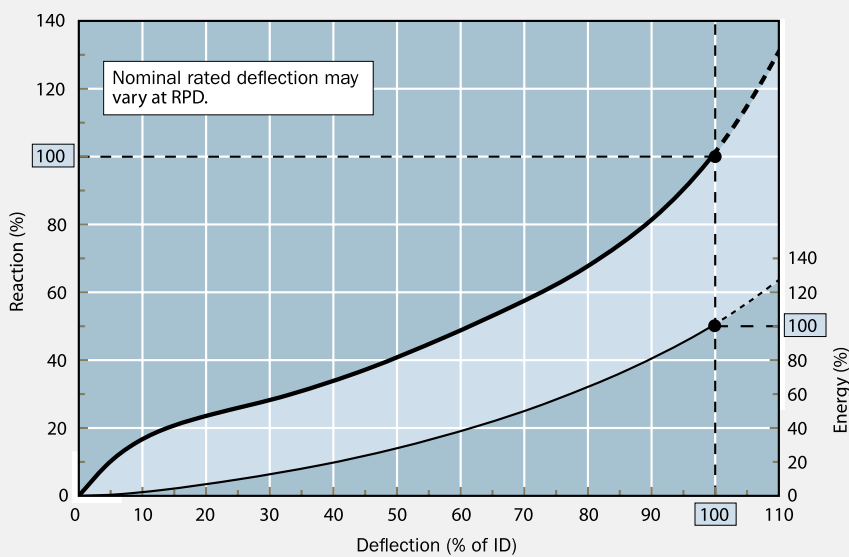

Cylindrical Fenders

LARGE CYLINDRICALS

OD	ID	L	BAR MATERIAL Gr. 8.8			BAR MATERIAL Gr. 45		
			ØB	CHAIN (SL2)	SHACKLE PIN Ø	ØB	CHAIN (SL2)	SHACKLE PIN Ø
800	400	1000	55	20	25	65	20	25
		1500	70	22	28	85	22	28
		2000	85	28	35	105	28	35
		2500	100	30	38	120	30	38
		3000	110	34	42	135	34	42
1000	500	1000	60	20	25	70	20	25
		1500	75	26	32	90	26	32
		2000	90	30	38	110	30	38
		2500	105	34	42	130	34	42
		3000	120	40	50	145	40	50
1200	600	1000	60	22	28	75	22	28
		1500	80	28	35	95	28	35
		2000	95	34	42	115	34	42
		2500	110	40	50	135	40	50
		3000	125	40	50	155	40	50
1400	800	1000	60	22	28	75	22	28
		1500	80	28	35	95	28	35
		2000	95	34	42	115	34	42
		2500	110	40	50	135	40	50
		3000	125	40	50	155	40	50
1600	800	1000	70	30	35	80	30	35
		1500	90	34	42	105	34	42
		2000	105	40	50	130	40	50
		2500	125	40	50	150	40	50
		3000	140	44	57	170	44	57

[Units: mm]

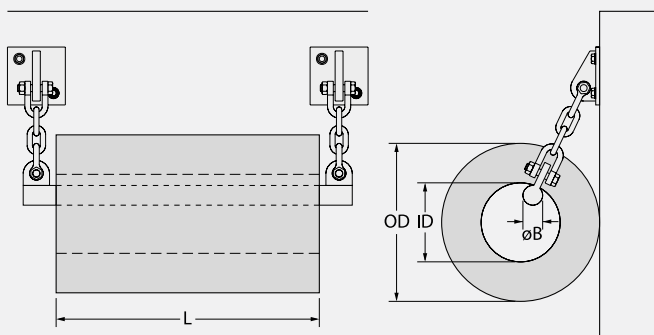

Large cylindricals (Ø900–Ø1600 mm) often use a central support bar connected at each end to chains which go back to brackets or U-anchors on the quay wall.

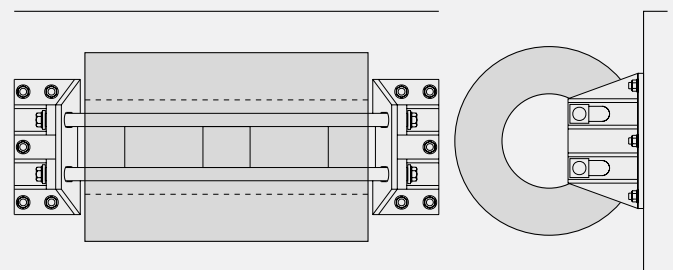

Very large cylindricals (≥Ø1600 mm) may require special ladder brackets due to their weight. These are specially designed for each application.

Cylindrical Fenders

SMALL CYLINDRICALS

OD	ID	CHAIN	SHACKLE
100	50	14	16
125	65	14	16
150	75	16	16
175	75	16	16
200	90	18	19
200	100	18	19
250	125	20	22
300	150	24	28
380	190	28	35
400	200	28	35
450	225	28	35
500	250	32	38
600	300	35	44

[Units: mm]

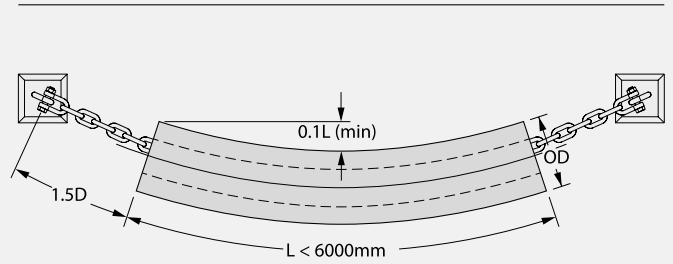

Small cylindricals ($\leq \text{Ø}600 \text{ mm}$) are often suspended from chains connected to brackets or U-anchors on the quay wall.



Extrusions



Extruded fenders are simple rubber profiles, usually attached with bolts to the structure.

Extrusions can be made in virtually any length then cut and drilled to suit each application. Pre-curved sections and special sizes are available on request. Usually black in colour, extruded fenders can also be supplied in creamy white as an option.

FEATURES

Wide range of standard sizes

Available in almost any length

Various fixing methods

Simple, robust design

Special pre-curves available

Black or creamy white

APPLICATIONS

Jetties and wharves for small craft

Tugs and workboats

Pontoon protection

Inland waterways

General purpose fendering



Extrusions

Square and D-section extruded profiles are widely used as beltings on tugs and other workboats. DC and SC fenders have a circular bore for extra wall thickness and durability. DD and SD fenders have a D-bore for securing with a flat bar.

Extruded fenders are available in many other sections as well. All can be cut to length, drilled, angle cut or pre-curved as required.

DC-FENDERS

A	B	øC	D ₁	øD	E	F	G	H	FLAT BAR	BOLT SIZE	WEIGHT
100	100	30	50	15	25	10	90-130	200-300	50 x 6	M12	10.1
150	150	65	75	20	30	12	110-150	250-350	60 x 8	M16	20.6
200	200	75	100	25	45	15	130-180	300-400	80 x 10	M20	38.5
250	250	100	125	30	50	20	140-200	350-450	100 x 10	M24	59.0
300	300	125	150	30	60	25	140-200	350-450	110 x 12	M24	83.7
350	350	150	175	35	70	25	140-200	350-450	120 x 12	M30	113
400	400	175	200	35	80	30	140-200	350-450	130 x 15	M30	146
400	400	200	200	35	80	30	140-200	350-450	130 x 15	M30	137
500	500	250	250	35	100	30	140-200	350-450	130 x 15	M36	214

[Units: mm, kg/m]

SC-FENDERS

A	B	øC	D ₁	øD	E	F	G	H	FLAT BAR	BOLT SIZE	WEIGHT
100	100	30	50	15	25	10	90-130	200-300	50 x 6	M12	11.4
150	150	65	75	20	30	12	110-150	250-350	60 x 8	M16	23.6
200	200	75	100	25	45	15	130-180	300-400	80 x 10	M20	43.8
200	200	100	100	25	40	15	130-180	300-400	80 x 10	M20	39.5
250	250	100	125	30	50	20	140-200	350-450	100 x 10	M24	67.2
300	300	125	150	30	60	25	140-200	350-450	110 x 12	M24	95.6
350	350	150	175	35	65	25	140-200	350-450	120 x 12	M30	126
350	350	175	175	35	65	25	140-200	350-450	120 x 12	M30	121
400	400	200	200	35	70	30	140-200	350-450	130 x 15	M30	158
500	500	250	250	45	90	40	150-230	400-500	150 x 20	M36	247

Other dimensions of SC fenders, e.g. 165x125, 250x200, 300x250, are available upon request.

[Units: mm, kg/m]

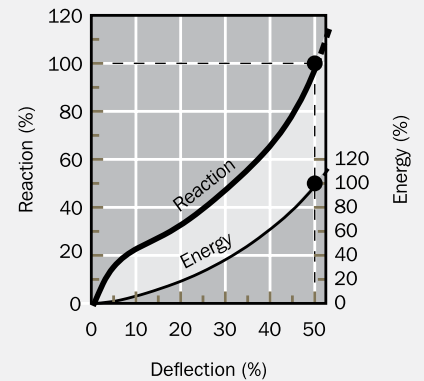

PERFORMANCE

FENDER SIZE	DC		SC	
	E	R	E	R
100 x 100 ø30	1.9	157	2.7	173
150 x 150 ø65	4.2	235	6.4	259
200 x 200 ø75	7.5	314	6.7	261
200 x 200 ø100	-	-	11.3	345
250 x 250 ø100	11.7	392	17.7	431
300 x 300 ø125	16.9	471	25.5	518
350 x 350 ø150	22.9	549	21.0	423
350 x 350 ø175	-	-	34.3	604
400 x 400 ø200	29.4	628	45.1	690
500 x 500 ø250	46.0	785	70.5	863

Values are per meter

[Units: kNm, kN]

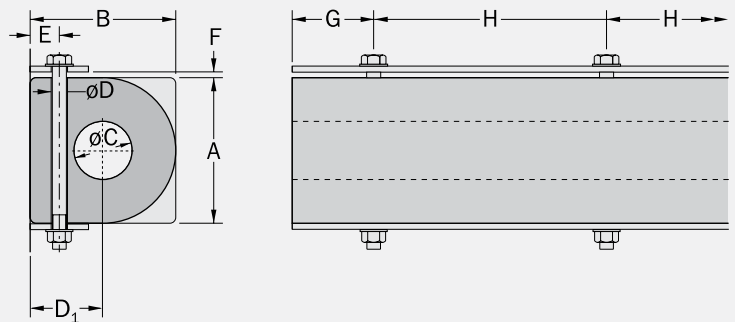

Extrusions

DD-SERIES

A	B	øC	D	øE	øF	G	H	FLAT BAR	BOLT SIZE	WEIGHT
80	70	45	30	30	15	90-130	200-300	35 x 5	M12	4.8
100	100	50	45	30	15	90-130	200-300	40 x 5	M12	8.5
125	125	60	60	40	20	110-150	250-300	50 x 6	M16	13.2
150	150	75	75	40	20	110-150	250-300	60 x 8	M16	18.5
200	150	100	80	50	25	130-180	300-400	80 x 10	M20	23.1
200	200	100	100	50	25	130-180	300-400	80 x 10	M20	32.9
250	200	125	100	60	30	140-200	350-450	90 x 12	M24	39.9
250	250	125	125	60	30	140-200	350-450	90 x 12	M24	51.5
300	300	150	150	60	30	140-200	350-450	110 x 12	M24	74.1
350	350	175	175	75	35	140-200	350-450	130 x 15	M30	101
380	380	190	190	75	35	140-200	350-450	140 x 15	M30	119
400	300	175	150	75	35	140-200	350-450	130 x 15	M30	99
400	400	200	200	75	35	140-200	350-450	150 x 15	M30	132
500	500	250	250	90	45	160-230	400-500	180 x 20	M36	206

[Units: mm, kg/m]

SD-SERIES

A	B	øC	D	øE	øF	G	H	FLAT BAR	BOLT SIZE	WEIGHT
100	100	50	45	30	15	90-130	200-300	40 x 5	M12	9.9
150	150	70	65	40	20	110-150	250-300	50 x 8	M16	22.7
165	125	80	60	40	20	110-150	250-300	60 x 8	M16	20.3
200	150	90	65	50	25	130-180	300-400	70 x 10	M20	30.8
200	200	90	95	50	25	130-180	300-400	70 x 10	M20	39.8
250	200	120	95	60	30	140-200	350-450	90 x 12	M24	49.4
250	250	120	120	60	30	140-200	350-450	90 x 12	M24	61.1
300	250	140	115	60	30	140-200	350-450	100 x 12	M24	75.0
300	300	125	135	60	30	140-200	350-450	100 x 12	M24	92.0
400	400	200	200	75	35	140-200	350-450	150 x 15	M30	153
500	500	250	250	90	45	160-230	400-500	180 x 20	M36	239

[Units: mm, kg/m]

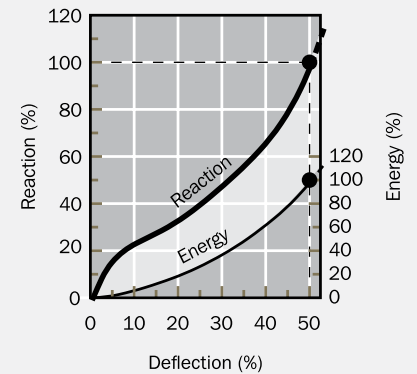

PERFORMANCE

FENDER SIZE	D		D	
	E	R	E	R
80	0.9	62	-	-
100	1.4	77	2.7	136
125	2.2	97	-	-
150	3.2	115	6.4	206
165	-	-	7.4	224
200	5.7	153	11.3	275
250	8.9	191	17.6	343
300	12.9	230	25.5	412
350	17.6	268	34.3	471
380	20.0	292	-	-
400	23.0	306	45.2	589
500	35.9	383	70.7	736

Values are per meter

[Units: kNm, kN]

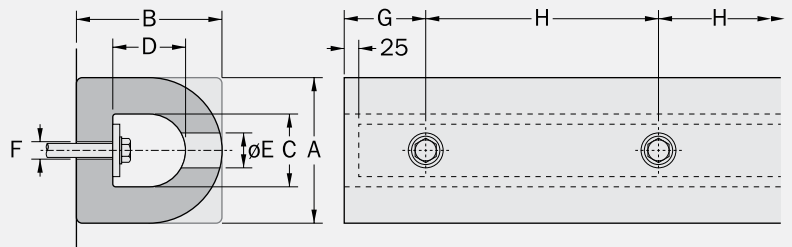

Composite Fenders

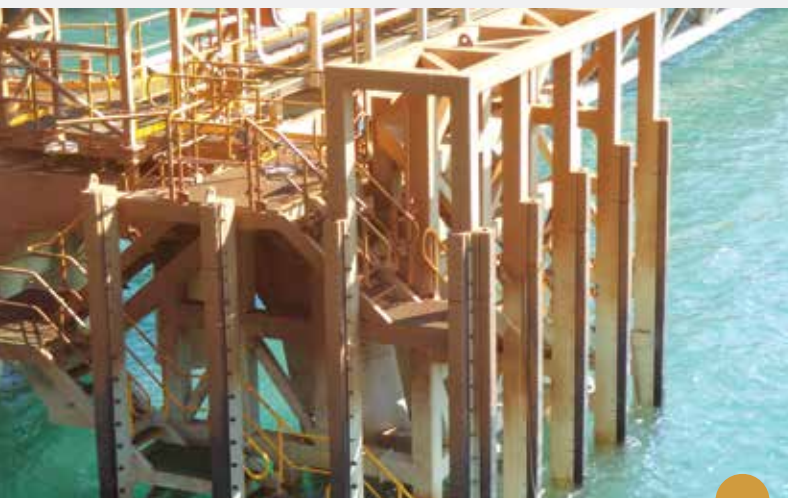

Composite fenders, also called Rubbylene[®], are composites of rubber for resilience and UH MWPE for low-friction and wear resistant properties.

The two materials are bonded with a special vulcanizing method which is stronger and more reliable than a mechanical joint. Composite fenders are used where the simplicity of extrusions are required but with lower shear forces.

FEATURES

Resilient rubber body

Low-friction UHMW-PE face

Strong molecular bond

Easily drilled and cut

Many standard sizes

APPLICATIONS

Jetties and wharves for small craft

Mooring pontoons

Pile guides on floating structures

Inland waterways

Composite Fenders

SHEAR DEFORMATIONS

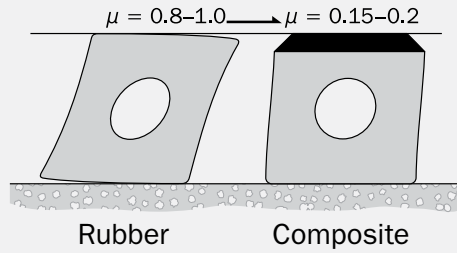

CF-A SERIES

CF-B SERIES

A	B	øC*	t	øD	E	F	G	H	FLAT BAR	BOLT SIZE	STD LENGTH	WEIGHT	
												CF-A	CF-B
100	100	30	20	15	25	10	90-130	200-300	50 x 6	M12	3000	10.3	11.1
150	150	65	20	20	30	12	110-150	250-350	60 x 8	M16	3000	21.5	27.0
165	125	65	20	20	35	15	110-150	250-350	60 x 8	M16	3000	19.2	24.8
200	200	75	25	25	45	20	130-180	300-400	80 x 10	M20	3000	40.2	48.0
200	200	100	25	25	45	20	130-180	300-400	80 x 10	M20	3000	36.2	48.0
250	250	100	30	30	50	25	140-200	350-450	100 x 10	M24	2000	60.2	75.0
300	300	125	30	30	60	30	140-200	350-450	110 x 12	M24	3700	92.1	108

* Dimension only applies to CF-A fender.

[Units: mm, kg/m]

PERFORMANCE

	CF-A ¹		CF-B ²	
	E	R	E	R
100 x 100	4.0	222	5.6	370
150 x 150	10.5	312	12.5	555
165 x 125	10.9	373	13.2	705
200 x 200 (ø75)	11.5	334	22.2	741
200 x 200 (ø100)	16.0	452	-	-
250 x 250	24.3	565	34.7	926
300 x 300	42.0	624	50	1111

Values are per meter.

[Units: kNm, kN]

	CF-C ¹		CF-D ²	
	E	R	E	R
80 x 80	1.6	76	2.8	297
100 x 100	2.2	154	4.4	370
120 x 120	3.0	188	6.4	445
150 x 150	6.0	377	10.0	556

Values are per meter.

[Units: kNm, kN]

¹ Performance values are at bore closure.

² Performance values are at 30% deflection.

Composite fenders are supplied undrilled. Drilled and counterbored holes, special cuts, etc are available on special request.

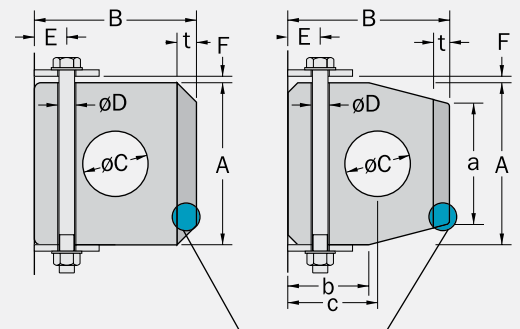
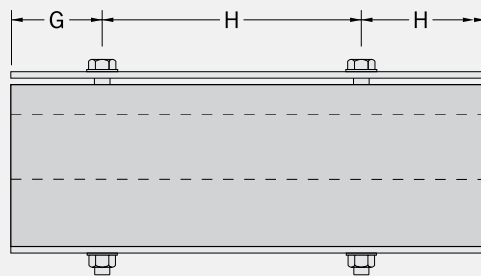

UHMW-PE face (black as standard)

CF-C SERIES

CF-D SERIES

A	B	øC*	a	b	c	t	øD	E	F	G	H	FLAT BAR	BOLT SIZE	STD LENGTH	WEIGHT	
															CF-C	CF-D
80	80	42	60	40	44	10	15	25	6	90-130	200-300	45 x 6	M12	2000	5.4	7.0
100	100	45	74	50	56	10	15	25	8	90-130	200-300	45 x 6	M12	2000	8.4	11.0
120	120	62	88	60	67	12	20	30	10	110-150	250-350	60 x 8	M16	2000	12.2	15.8
150	150	73	110	75	83	15	20	30	12	110-150	250-350	60 x 8	M16	3000	19.7	24.8

* Dimension only applies to CF-C fender.

[Units: mm, kg/m]

Heavy Duty Molded Fenders



Heavy duty (MD) fenders are designed to perform in the toughest environments.

The through-bolt fastening arrangement on both sides of the fender along with the embedded steel plate offer superior strength compared to standard D-shaped fenders whilst offering comparable performance.

MD fenders can withstand most vertical impacts during events such as when other vessel beltings overlap the fender and can also be attached to steel hull beltings to increase outstand and offer additional vessel protection. MD fenders can act as berthing fenders for situations where there are no jetty fenders in remote locations, thus, avoiding the need to deploy roped temporary boat fenders.

FEATURES

Resilient D-shaped molded rubber body

Embedded steel plate for through bolt fastening

Double-bolted arrangement for extra strength

Recessed bolt holes to avoid rope snagging

End plugs available

APPLICATIONS

Tug vessel flat-sided hulls

Fishing vessels

Small ferries & catamarans

Heavy Duty Molded Fenders

DIMENSIONS

	A	B	ØC	D	E	P x Q	F	G	H	L _{max}	T	BOLT SIZE	WEIGHT
MD300	300	360	125	200	280	26 x 35	175	500	175	3500	40	M24 (W7/8")	140
MD400	400	500	200	300	410	30 x 40	150	500	150	3000	50	M27 (W1")	260
MD500	500	562	200	300	472	30 x 40	150	500	150	2500	50	M27 (W1")	360
MD550	550	700	300	420	550	55 x 75	150	500	360	3000	75	M52 (W2")	480
MD600	600	700	300	420	550	55 x 75	150	500	360	3000	125	M52 (W2")	530

[Units: mm, kg/m]

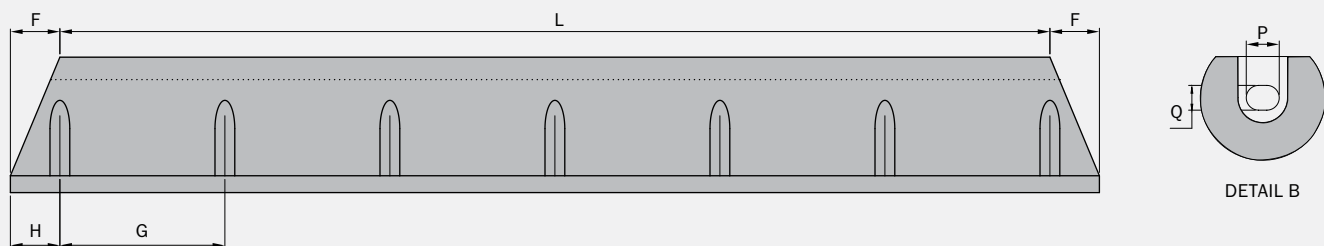
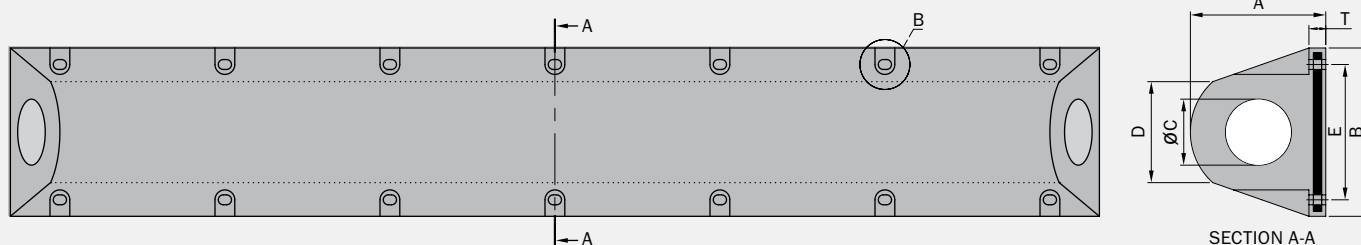

FENDER SIZE	ENERGY	REACTION	DEFLECTION
MD300	15.7	251	125
MD400	58.32	583	200
MD500	56.7	568	200
MD550	178	1186	300
MD600	164	1098	300

[Units: kNm/m, kN/m, mm]

Fender Bars



Fender bars are available in two different versions:

ML-type for exposed locations and MLS-type for low reaction, visibility and nonmarking. All fender bars can resist high impacts and are suitable for a wide range of general purpose applications.

ML FENDER BARS

The ML fender bar is intended for heavy duty applications – everything from ferry berths to bumpers on barges. The vulcanized internal steel plate provides very strong fixing points and reduces bending moments in the bolts.

MLS FENDER BARS

MLS Fender Bars have a special modified profile to reduce reaction forces and allow a high degree of flexibility in all directions. Being softer, MLS fender bars are ideal for protecting smaller workboats, pontoons and load-sensitive structures.

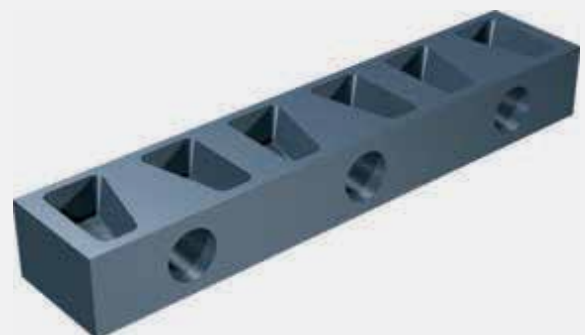

Fender Bars

DIMENSIONS

TYPE	W	H	L	A	B	ANCHORS	WEIGHT
ML	150	150	1000	250	500	2 x M24	38
ML	150	150	1500	250	500	3 x M24	56
ML	150	200	1000	250	500	2 x M24	43
ML	150	200	1500	250	500	3 x M24	65
ML	200	200	1000	250	500	2 x M30	65
ML	200	200	1500	250	500	3 x M30	98
ML	200	250	1000	250	500	2 x M30	77
ML	200	250	1500	250	500	3 x M30	116
ML	200	300	1000	250	500	2 x M30	88
ML	200	300	1500	250	500	3 x M30	132
MLS	200	300	1000	250	500	2 x M30	63
MLS	200	300	1500	250	500	3 x M30	95

PERFORMANCE

E	R
16.7	638
24.5	961
16.7	441
24.5	667
26.5	824
40.2	1236
26.5	657
40.2	991
26.5	530
40.2	795
23.0	355
38.0	593

Please ask for other dimensions

[Units: mm, kg]

[Units: kNm, kN]

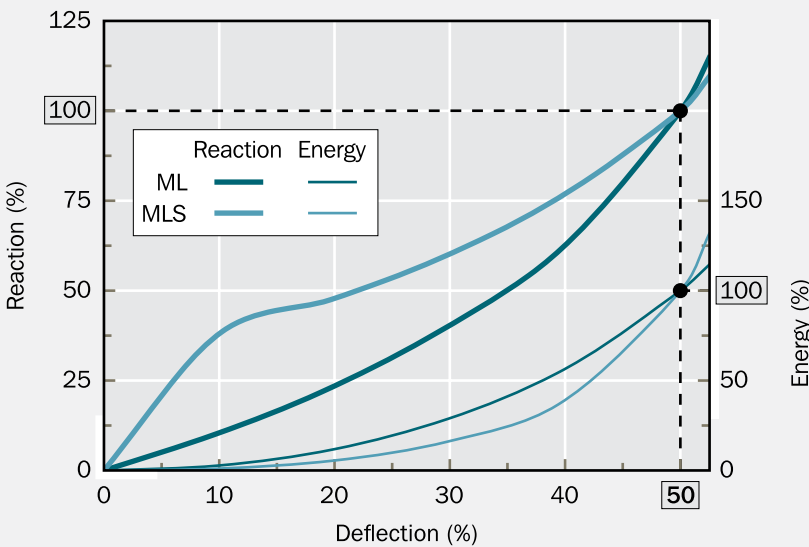
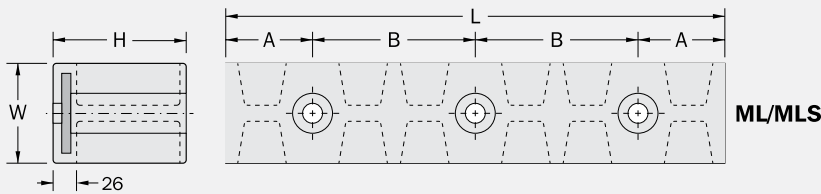

STRONG FIXINGS

Fender bars have a low-profile fixing which prevents bending of the bolt even under large deflections and shear. With timber fenders the bolts easily bend and the wood cracks and splinters.

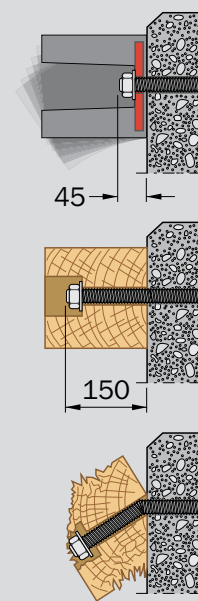

Marine Protection Plates



Marine protection plates (MPP) are resilient bumpers designed for quays where small vessels are moored, protecting both the quay face and vessel from abrasion. MPP fenders have also been used at the push knee on some tugs.

MPP are ideal for applications where the distance between the boat and dock must be minimized. The design includes a heavy-duty steel back plate which is vulcanized into the rubber body so only a few fixing bolts are required.

MPP are available with a flat or wave-patterned surface design.

FEATURES

Heavy duty steel

Long lasting

Easy to install

Custom-made rubber surface

Customized dimensions

Superior quality rubber body with high abrasion resistance

APPLICATIONS

Pontoon protection

Dock, jetty and monopiles protection where small vessels are moored

Ideal for applications where distance reduction between boat and dock are required

Marine Protection Plates

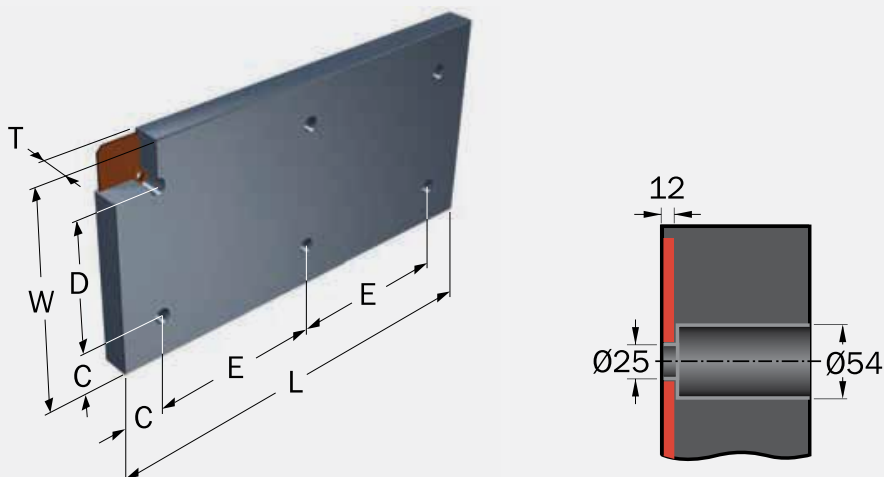

TYPE	T	W	L	C	D	E	ANCHORS	WEIGHT
MPP	50	500	1000	100	300	800	4 x M20	45
		600		150		700		54
		750		450		700		67
MPP	50	500	1500	100	300	650	6 x M20	67
		600		150		600		80
		750		150		450		600
MPP	75	500	1000	100	300	800	4 x M20	59
		600		150		700		71
		750		450		700		88
MPP	75	500	1500	100	300	650	6 x M20	88
		600		150		600		106
		750		150		450		600
MPP	100	500	1000	100	300	800	4 x M20	73
		600		150		700		88
		750		450		700		109
MPP	100	500	1500	100	300	650	6 x M20	109
		600		150		600		131
		750		150		450		600
MPP	125	500	1000	100	300	800	4 x M20	87
		600		150		700		104
		750		450		700		130
MPP	125	500	1500	100	300	650	6 x M20	130
		600		150		600		156
		750		150		450		600
MPP	150	500	1000	100	300	800	4 x M20	100
		600		150		700		121
		750		450		700		151
MPP	150	500	1500	100	300	650	6 x M20	151
		600		150		600		181
		750		150		450		600

Tailor-made corner elements and other dimensions available on request.

[Units: mm, kg]

Ramp and Cope Protections

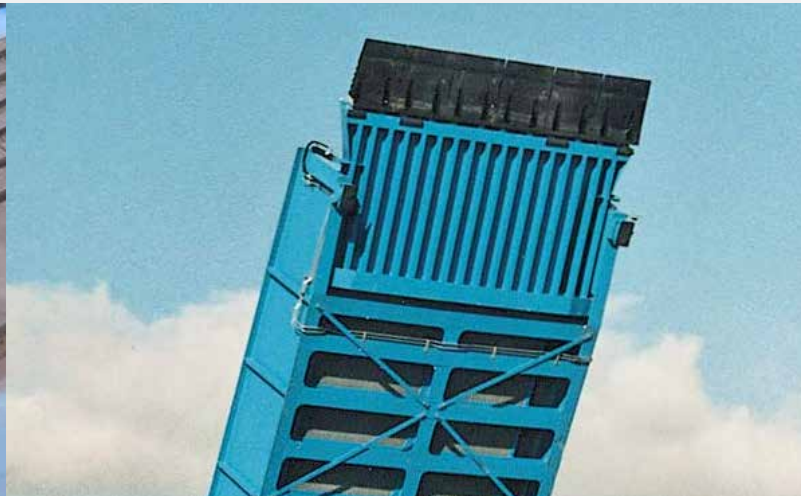

Ramp and cope protectors are special wedge-shaped rubber elements which are fitted together to form a flexible extension to steel and concrete structures.

Their internal steel plate gives a strong connection and the grooved rubber face provides a high friction surface that prevents slipping.

FEATURES

Superior quality rubber body

High wear resistance

Long lasting

Easier to install

Low noise compared to steel ramp

Customized dimensions

Lighter than steel ramp

APPLICATIONS

Pontoon protection

Dock, jetty and monopoles protection

Distance reduction between vessel and dock

Ramp and Cope Protections

RAMP PROTECTORS

Used as ramp protectors, they allow easy loading and unloading of vehicles and trailers whilst protecting the front edge of the ramp from wear. Noise levels are also much lower compared to steel ramps. Ramp protectors weigh much less than steel too – so they are easier to install and place less stress on the structure.

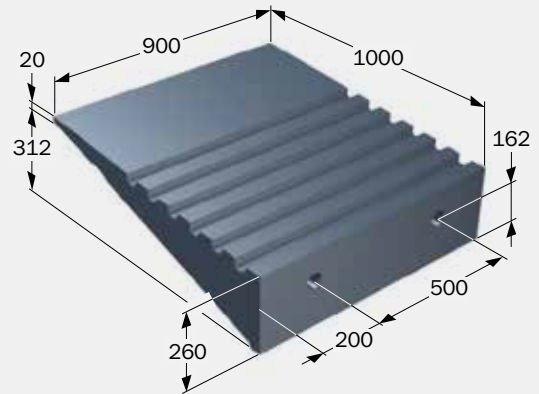

RCP-1000 shown.
Other dimensions are available on request.

COPE PROTECTORS

Used as cope protectors, the elements form a flexible extension to the cope or top edge of the quay. This reduces the gap between quay face and ship where loose or bulk cargoes can fall into the harbour. Cope protectors are also flexible, so will bend out of the way if hit by a ship during berthing.

Due to their flexibility, cope protectors are not designed to support the weight of people, vehicles, etc.

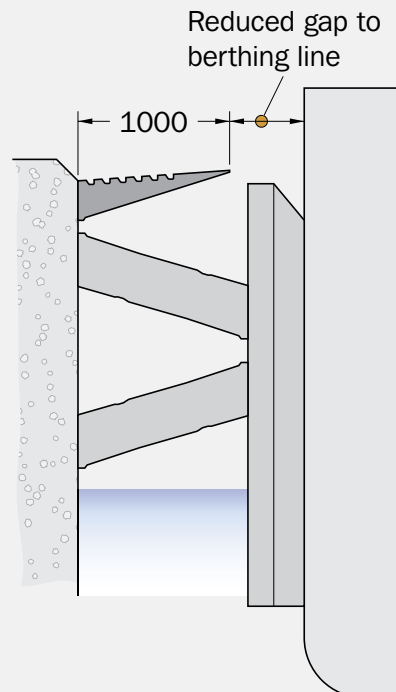
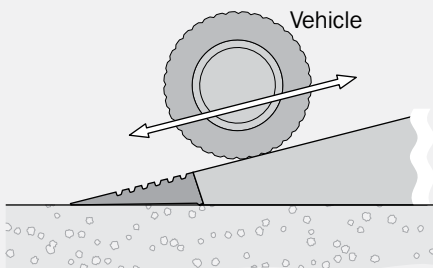

Shear Fenders



Shear fenders are unique because they have a linear load-deflection characteristic in shear but remain stiff in compression to support heavy loads.

Their simple concept makes shear fenders easy to install and ideal for low energy applications. The top and bottom steel plates are fully encased in rubber which protects them from corrosion and minimizes maintenance.

Piles and simple frontal panels are often used in conjunction with shear fenders. Movement in shear should be limited by chains or other mechanical.

FEATURES

Linear reaction curve

Omnidirectional

Supports large weights

APPLICATIONS

General cargo berths

Ferry terminals

Offshore boat landings

Bridge protection

Pontoon yokes

Shear Fenders

TYPE-SF SHEAR FENDER

FENDER	A	B	E	F	G	H	J	T	ØS	BOLT	WEIGHT
SF 400-180	525	525	–	405	405	180	136	22	400	M24	115
SF 500-260	700	550	80	430	440	260	190	35	500	M30	190
SF 500-275	610	610	–	510	510	275	231	22	500	M24	183

[Units: mm, kg]

FENDER	SHEAR			COMPRESSION		
	D _S	E _S	R _S	D _C	E _C	R _C
SF 400-180	136	10.0	147	20	1.2	118
SF 500-260	190	23.8	250	29	3.8	265
SF 500-275	231	24.9	216	35	4.5	255

[Units: mm, kNm, kN]

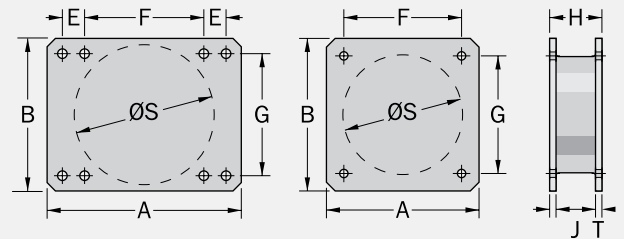

TYPE-E46 SHEAR FENDER

FENDER	W	W _R	H	L	A	B	C	ØD	E	BOLT	WEIGHT
E46498	305	350	352	489	21	127	430	127	310	M22	77
E46502	406	505	471	641	24	178	575	178	423	M25	136

[Units: mm, kg]

FENDER	SHEAR			COMPRESSION		
	D _S	E _S	R _S	D _C	E _C	R _C
E46498	484	14.0	57.9	155	2.5	61.8
E46502	660	32.7	99.0	212	6.2	116

[Units: mm, kNm, kN]

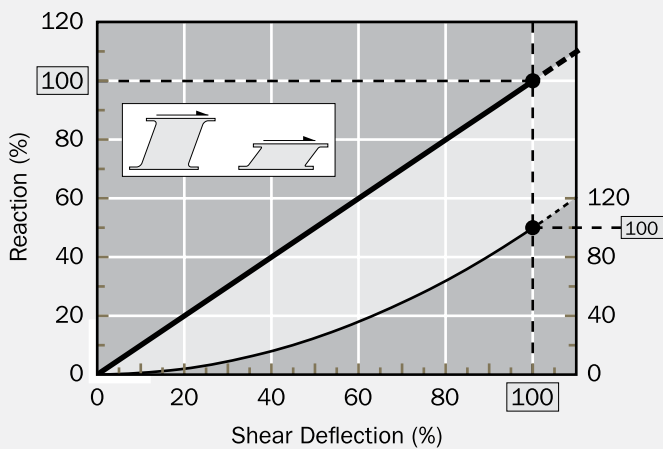
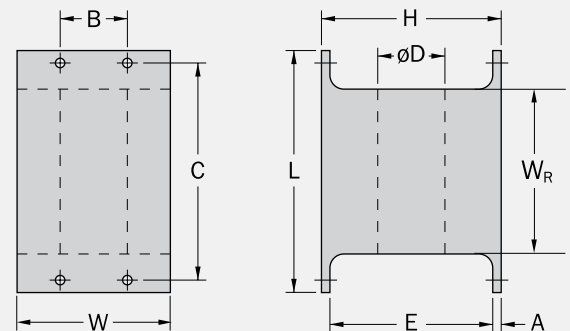

Note: Nominal rated deflection may vary at RPD.

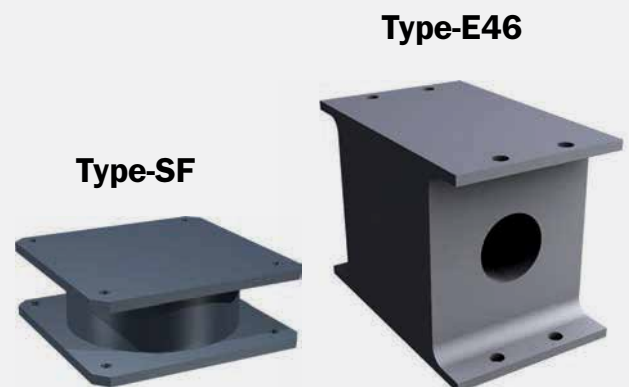

Tug Fenders



Tug fenders must work harder, for longer and under more extreme conditions than any other fender type. Tugs may be fitted with up to four types of fender – each type serving a particular application.

As many tugs become more powerful, some exceeding 100t bollard pull, choosing the right type, size and arrangement of fenders becomes critical.

Note: HPSAR tug cylindrical fenders are available.
Please refer to page 5 - 6.

When selecting fenders, designers should consider:

- Bollard pull
- Initial contact loads
- Dynamic load effects
- Friction requirements
- Pushing angles
- Hull attachment
- Fender tolerances
- Material quality
- Spares availability

Tug Fenders



1 Cylindrical fenders

Fitted to the bow / stern of tugs and usually used to push against flared hulls and in open sea conditions.

2 Pushing fenders

Block, cube and W- and M-fenders provide large contact surfaces for low hull pressures. Their grooved surfaces provide exceptional grip.

3 Side beltings

D, square and wing-D fenders are often used as side beltings to protect the vessel during escort duties and when coming alongside.

4 Transition blocks

Transition blocks are used to provide a smooth interface between side beltings and bow/stern fenders.

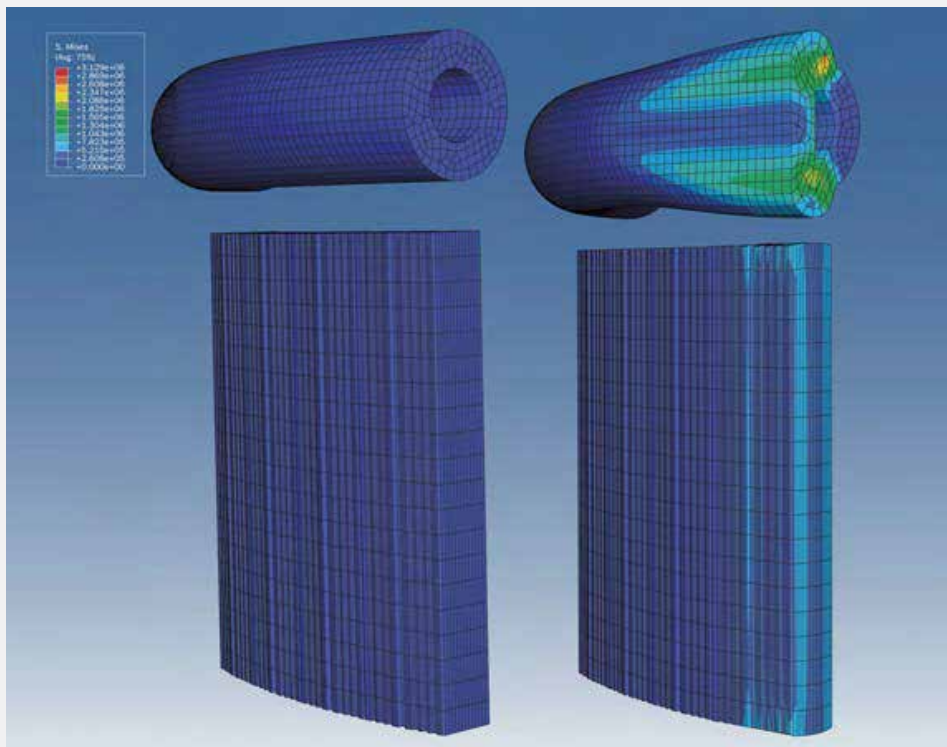

ABAQUS finite element analysis of true hull shapes and fender arrangements

Tug Cylindricals



Large cylindrical fenders are often used as the primary pushing fenders on the bow or stern of modern tugs. Their round shape is ideal for working with large bow flares (like container ships), but are equally good for pushing flat-sided vessels.

Tug cylindricals come in diameters to 1000 mm and in very long continuous or spigot-joined lengths. A longitudinal chain runs down the centre of the fender, supplemented by circumferential straps or chains which are recessed into grooves. Tapered ends are also available.

FEATURES

Heavy-duty design

Soft, flexible face

Grooved for extra grip

Low weight per m²

Fits around tight bends

APPLICATIONS

All types of tug

Pontoon protection

Special corner fenders

Ocean-going tugs

Pontoon yokes

Note: HPSAR tug cylindrical fenders are available. Please refer to pg 5 - 6.

Tug Cylindricals

$\varnothing D$	$\varnothing d$	d	A	B_{max}	C	$\varnothing G$	$\varnothing J$	WEIGHT
250	125	125	200	570	500	190	75	45.5
300	150	150	225	600	700	225	75	65.2
380	190	190	280	650	800	280	100	105
400	200	200	300	670	800	300	100	116
450	225	225	300	700	850	350	100	147
500	250	250	300	730	900	375	100	181
600	300	300	350	800	900	450	125	255
800	400	400	350	930	1000	600	125	453
900	450	450	350	1000	1100	675	150	573
1000	500	500	350	1060	1200	750	150	707

Groove size varies according to attachment method.
 Lengths 2 – 10m in one section, spigot joined for longer lengths.

[Units: mm, kg/m]

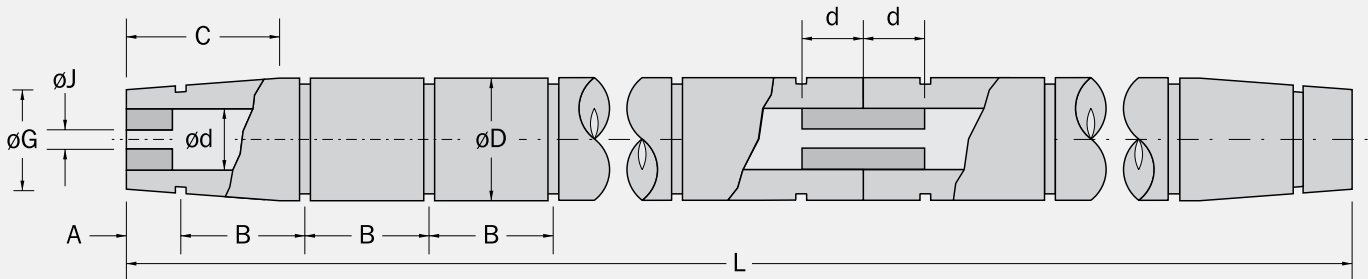

Attachment

Smaller fenders (≤ 500 mm diameter) are usually fixed by a longitudinal chain through the bore of the fender, connected to the hull by turnbuckles to tension the chain. Larger fenders often use supplementary chains or straps around the fender.

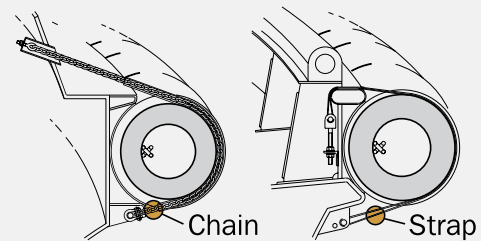

Curve Radius

Tug cylindrical fenders are made in straight lengths but can be pulled around the bow or stern radius.

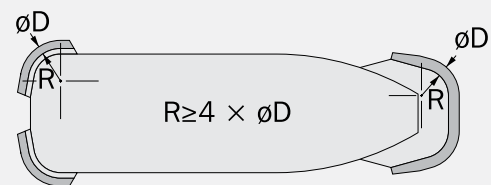

M-Fenders



M-fenders have a large and flexible contact face which exerts low pressure during pushing operations.

The grooves provide extra grip and the triple legs give a strong attachment to the tug. M-fenders can also be fitted around tight curves, whilst their relative low weight adds to tug stability.

FEATURES

- Heavy-duty design
- Triple-leg attachment
- Soft, flexible face
- Grooved for extra grip
- Low weight per m²
- Fits around tight bends

APPLICATIONS

- All types of tug
- Pontoon protection
- Special corner fenders

Note: M-Fenders and W-Fenders are not interchangeable.

M-Fenders

DIMENSIONS

TYPE	A	B	C	ØD	E	F	L _{max}	WEIGHT
M400	400	200	40	23	50	150	3000	56
M500	500	250	50	27	60	190	2900	89
M600	600	300	60	33	70	230	3400	132
M800	800	400	80	44	95	305	2000	235

[Units: mm, kg/m]

FIXING

PIN	FLAT BAR	R _{min}
Ø20	100 x 15	450
Ø24	125 x 20	550
Ø30	150 x 20	650
Ø40	150 x 20	900

[Units: mm]

PERFORMANCE GRAPH

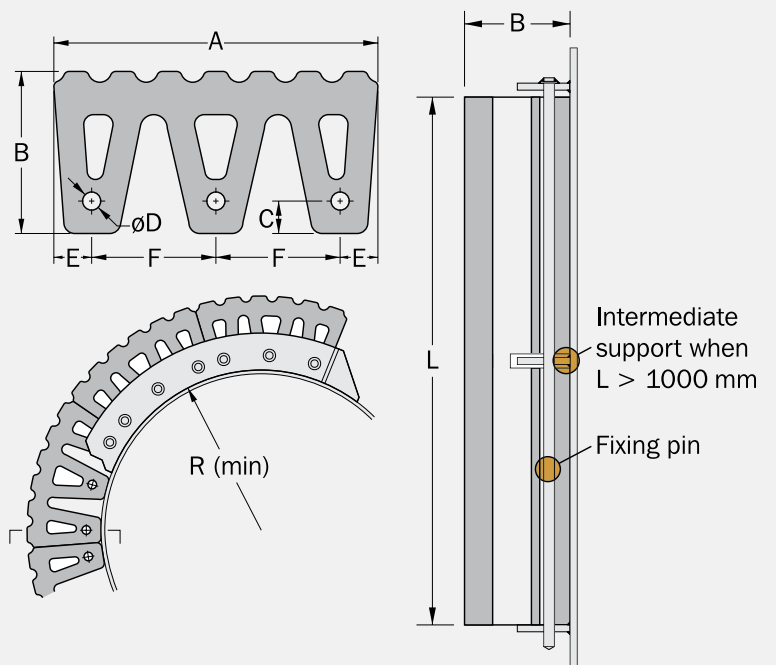
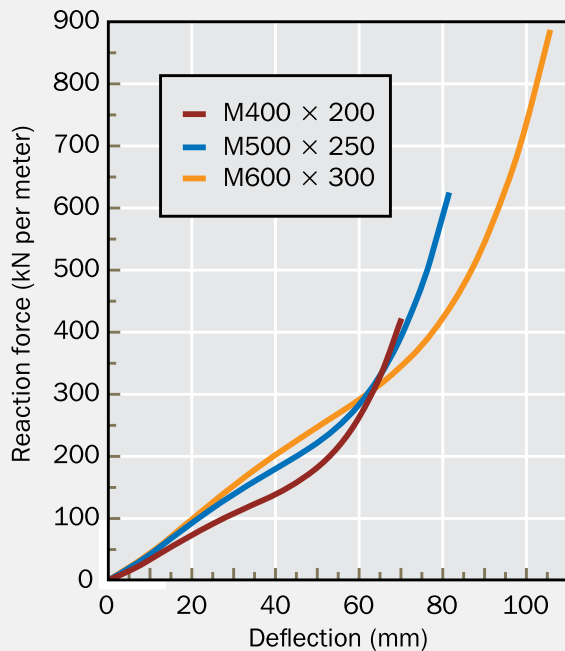

W-Fenders



W-fenders are made for the most extreme operating conditions.

The W-fender is one of the most successful fenders for tugs in the world today. It has a unique 'open bore' design which makes installation very simple. The flexible legs allow W-fenders to be curved around most hull shapes.

FEATURES

- Extreme-duty design
- Twin-leg attachment
- Open bore for easy installation
- Grooved for extra grip
- Fits around tight bends

APPLICATIONS

- All types of tugs
- Ocean-going tugs
- Icebreakers
- Large harbour tugs
- Bridge and pile protection

W-Fenders

DIMENSIONS

TYPE	A	B	C	D	E	F	K	L _{max}	WEIGHT
W32-20	320	200	280	180	100	67	50	2900	51
W40-25	400	250	350	220	110	75	55	2000	81
W48-30	480	300	426	269	135	90	65	3000	120
W50-45	500	450	420	255	90	100	75	2000	180

[Units: mm, kg/m]

FIXING

PIN	FLAT BAR	R _{min}
Ø25	100 x 20	600
Ø30	120 x 20	800
Ø40	140 x 20	900
Ø40	150 x 20	1000

[Units: mm]

PERFORMANCE GRAPH

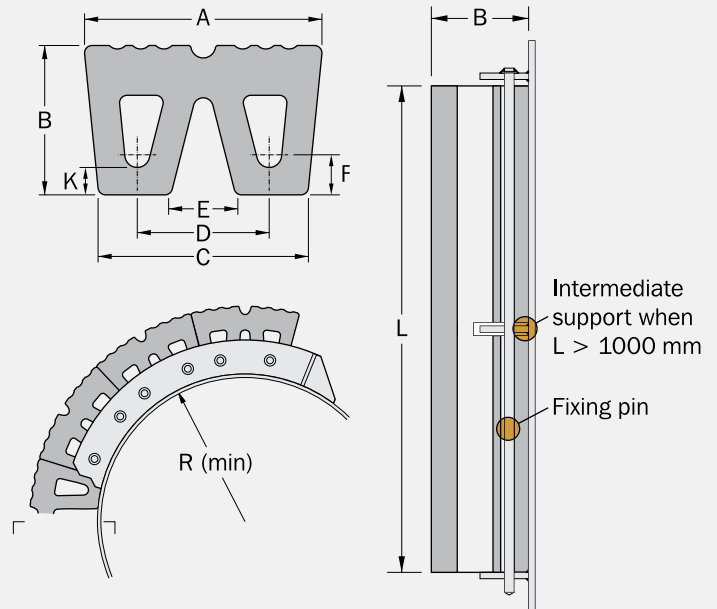
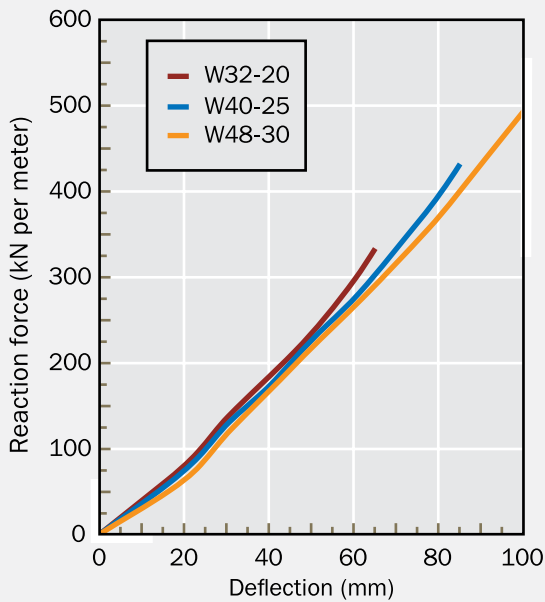

Keyhole Fenders



Block and cube fenders have a traditional 'keyhole' profile which is strong and ideal for heavy-duty applications.

There is a choice of grooved or flat face fenders depending on the required friction levels.

Where very low friction is needed, block and cube fenders can also be made as composite fenders with integral UHMW-PE faces. This is useful for tugs that operate in.

FEATURES

Heavy-duty design

Traditional, proven shape

Grooved or smooth face

Optional UHMW-PE face

APPLICATIONS

All types of tugs

Icebreaker

Ocean-going tugs

Pontoon protection

Large harbour tugs

Bridge and pile protection

Note: M-, W- and Keyhole fenders are not interchangeable.

Keyhole Fenders

DIMENSIONS

A	B	C	ØD	E	ØG	L _{max}	WEIGHT
200	200	35	28	130	90	2000	33
250	250	50	33	150	100	2000	54
300	300	60	33	180	115	1750	80
350	350	70	33	210	125	2000	114

[Units: mm, kg/m]

FIXING

PIN	FLAT BAR	R _{min}
Ø25	100 x 15	450
Ø30	125 x 20	600
Ø30	150 x 20	800
Ø30	175 x 20	1000

[Units: mm]

PERFORMANCE GRAPH

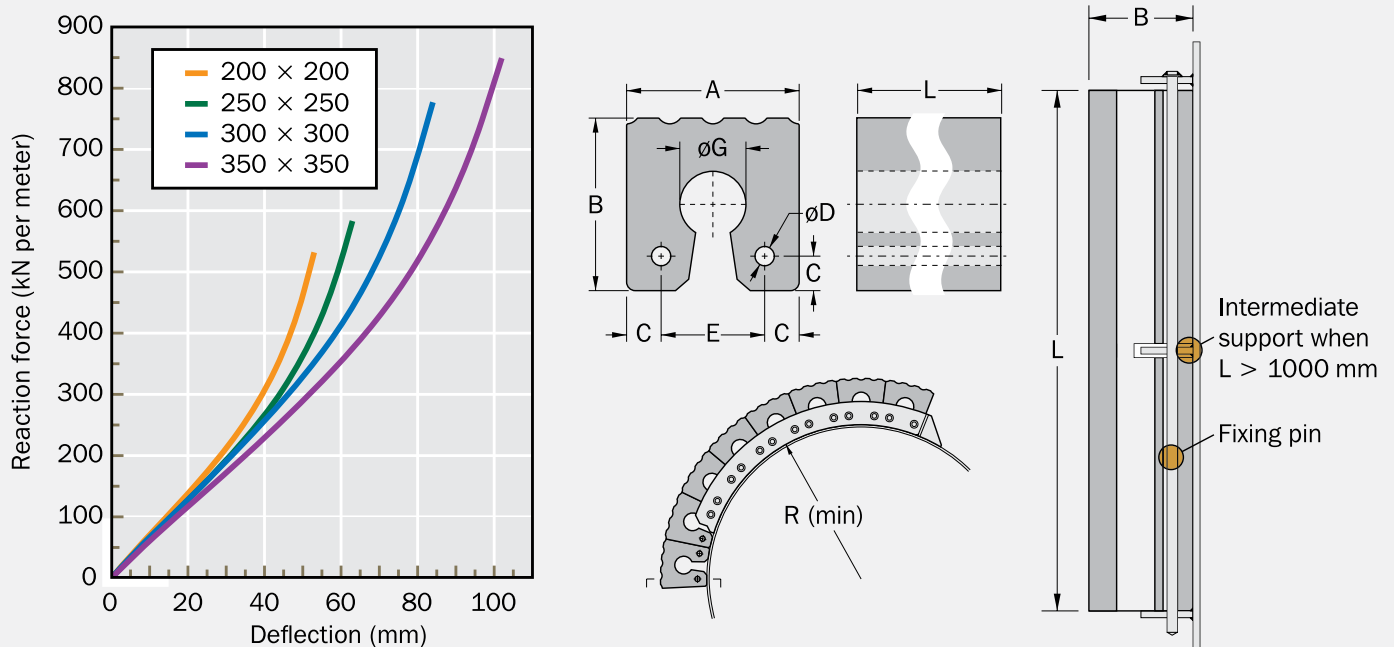

Accessories

Chains

Some fender systems need chains to help support heavy components or to control how the fender deflects and shears during impact. Open link or stud link chains are commonly used and these can be supplied in several different strength grades.

FEATURES

Choice of open or stud link chains

Various link lengths available

Proof load tested and certified

Galvanized as standard

Variety of matched accessories

APPLICATIONS

Large fender panels

Cylindrical fenders

Floating fender moorings

Safety applications

Lifting and installing

TYPICAL CHAIN SYSTEM

- 1 Anchors and fixing bolts
- 2 Chain bracket
- 3 Alloy D or bow-shackle with safety pin
- 4 Chain tensioner
- 5 Open or stud link chain
- 6 Frontal frame bracket
- 7 Frontal frame

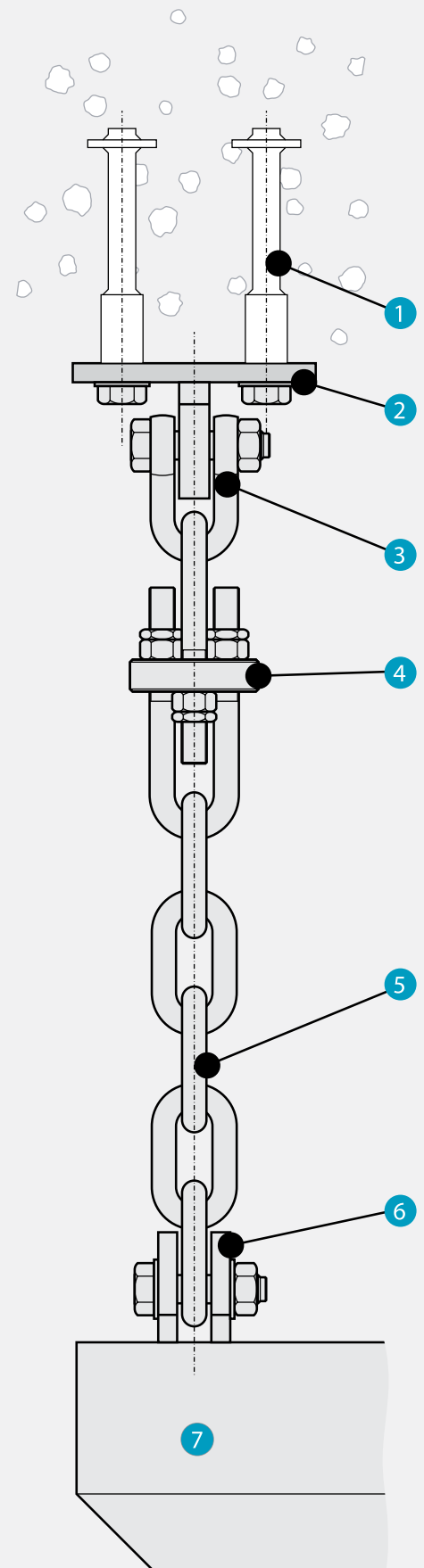

OPEN LINK CHAINS

ØC	3.0D LINKS			3.5D LINKS			4.0D LINKS			5.0D LINKS			MBL	
	L	W	WEIGHT	L	W	WEIGHT	L	W	WEIGHT	L	W	WEIGHT	SL2	SL3
14	42	18	0.2	49	20	0.2	56	20	0.2	70	21	0.3	124	154
16	48	21	0.3	56	22	0.3	64	22	0.3	80	24	0.4	160	202
18	54	23	0.4	63	25	0.4	72	25	0.5	90	27	0.5	209	262
20	60	26	0.5	70	28	0.6	80	28	0.6	100	30	0.8	264	330
22	66	29	0.7	77	31	0.8	88	31	0.8	110	33	1.0	304	380
25	75	33	1.1	88	35	1.1	100	35	1.2	125	38	1.5	393	491
28	84	36	1.4	98	39	1.6	112	39	1.7	140	42	2.0	492	616
30	90	39	1.8	105	42	2.0	120	42	2.1	150	45	2.5	566	706
32	96	42	2.2	112	45	2.4	128	45	2.5	160	48	3.0	644	804
35	105	46	2.8	123	49	3.1	140	49	3.3	175	53	4.0	770	964
38	114	49	3.6	133	53	3.9	152	53	4.3	190	57	5.1	900	1130
40	120	52	4.2	140	56	4.6	160	56	5.0	200	60	6.0	1010	1260
45	135	59	6.0	158	63	6.5	180	63	7.1	225	68	8.5	1275	1590
50	150	65	8.2	175	70	8.9	200	70	9.7	250	75	12	1570	1960
55	165	72	11	193	77	12	220	77	13	275	83	16	1900	2380
60	180	78	14	210	84	15	240	84	17	300	90	20	2260	2770

[Units: mm, kg/link, kN]

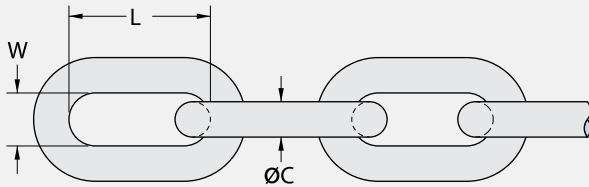

MBL = Minimum Breaking Load (kN)
 NBL = Nominal Breaking Load (kN)
 Tolerance: all dimensions ± 2.5%

STUD LINK CHAINS

ØC	COMMON LINK			MBL	
	L	W	WEIGHT	SL2 (U2)	SL3 (U3)
19	76	68	1	210	300
22	88	79	1	280	401
26	104	94	2	389	556
28	112	101	2	449	642
32	128	115	3	583	833
34	136	122	3	655	937
38	152	137	5	812	1160
42	168	151	6	981	1400
44	176	158	7	1080	1540
48	192	173	9	1270	1810
52	208	187	12	1480	2110
58	232	209	17	1810	2600
64	256	230	22	2190	3130
70	280	252	30	2580	3690
76	304	274	38	3010	4300
90	360	324	63	4090	5840

[Units: mm, kg/link, kN]

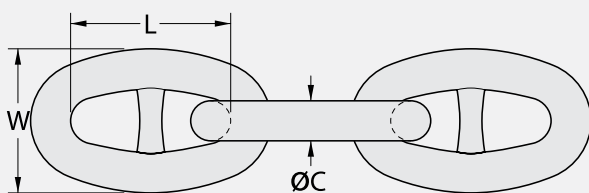

CHAIN TENSIONERS

CHAIN SIZE	ØA	L	W	WEIGHT
16	M16	200-240	40	3
18	M18	220-280	45	4
20	M20	235-305	50	5
22	M22	265-345	56	7
22	M24	280-370	60	9
25	M27	310-420	68	12
30	M30	345-465	76	17
32	M33	385-525	82	21
35	M36	420-560	90	27
40	M42	480-650	106	45
45	M48	545-745	120	64
50	M52	595-805	130	80
55	M56	640-880	140	99
60	M60	685-945	150	122
60	M64	730-1010	160	147

[Units: mm, kg]

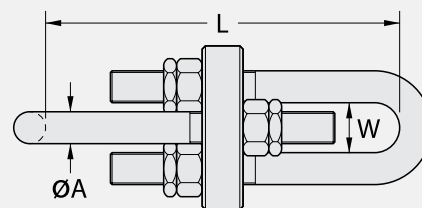

High Strength Shackles

ØD	ØF	ØH	G	DEE SHACKLE		BOW SHACKLE			NBL
				E	WEIGHT	E	ØJ	WEIGHT	
13	16	26	22	43	0.4	51	32	0.4	120
16	19	32	27	51	0.7	64	43	0.8	195
19	22	38	31	59	1.1	76	51	1.3	285
22	25	44	36	73	1.5	83	58	1.9	390
25	28	50	43	85	2.6	95	68	2.8	510
28	32	56	47	90	3.3	108	75	3.8	570
32	35	64	51	94	4.7	115	83	5.3	720
35	38	70	57	115	6.2	133	95	7.0	810
38	42	76	60	127	7.6	146	99	8.8	1020
45	50	90	74	149	13	178	126	15	1500
50	57	100	83	171	18	197	138	21	2100
57	65	114	95	190	28	222	160	29	2550
65	70	130	105	203	35	254	180	41	3330
75	80	150	127	230	60	330	190	65	5100
89	95	178	146	267	93	381	238	110	7200
102	108	204	165	400	145	400	275	160	9000

Please refer to your local office for detailed information

[Units: mm, kg, kN]

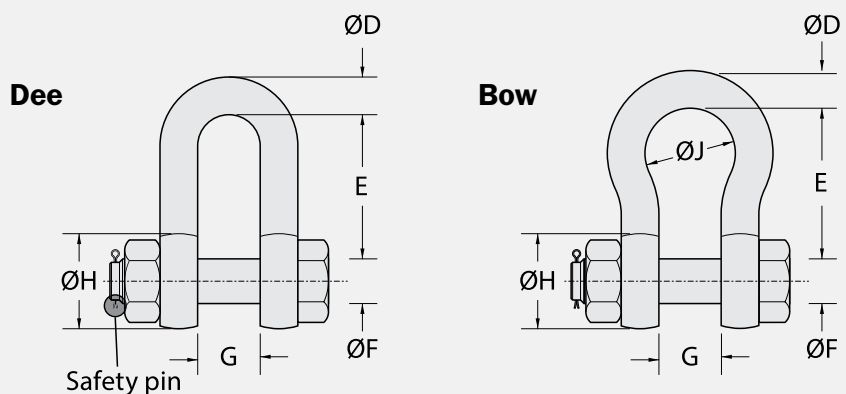

U-Anchors

ØD	E	F	G	J	K	t	WEIGHT	NBL
26	260	60	320	104	50	12	3.4	209
30	300	70	370	120	50	15	5.1	264
34	340	70	410	136	60	15	7.3	304
36	360	70	430	144	60	20	8.6	393
42	420	90	510	168	70	20	14	492
44	440	100	540	176	80	20	16	566
48	480	100	580	192	80	25	21	644
50	500	110	610	200	90	25	24	770
56	560	120	680	224	100	30	33	900
60	600	130	730	240	110	30	41	1010
66	660	140	800	264	120	35	55	1275
74	740	160	900	296	130	40	77	1570

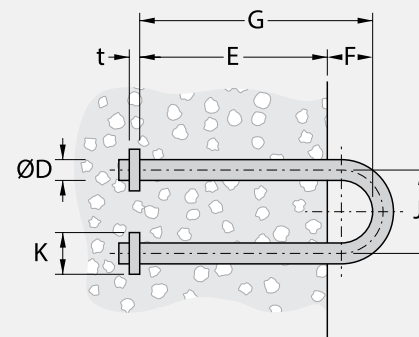

[Units: mm, kg, kN]

Anchors

NC3 ANCHORS

THREAD	A	C	ØF	L	S (sq)	T	WEIGHT
M20	40	60	30	200	63	10	1.1
M22	44	66	32	225	63	10	1.4
M24	48	73	36	250	75	10	1.9
M27	54	84	40	265	75	10	2.4
M30	60	95	45	270	100	10	3.5
M36	72	112	54	320	100	12	5.5
M42	84	134	63	360	100	12	8.1
M48	96	156	72	400	100	15	12
M56	112	182	84	550	120	15	20
M64	128	208	100	600	130	20	30
M76	152	242	114	700	150	20	46

Anchors available in mid steel, HDG, SS 316 or super duplex

[Units: mm, kg]

The NC3 is a traditional cast-in anchor design used for installing fenders to new concrete. The NC3 anchor has a threaded socket, a long tail and a square anchor plate. Non-standard sizes and other cast-in anchor types are available on request.

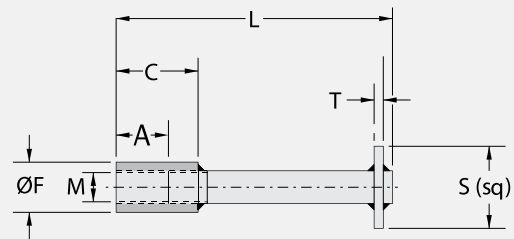

Always check min/max clamping thickness and socket depths actual threaded length on bolts.

EC2 ANCHORS

THREAD	B	E	G	J	L (typ.)	ØS	CAPSULE	WEIGHT
M12	110	5 – 8	10	2.5	–	15	1 × C12	0.15
M16	140	6 – 9	13	3	175	20	1 × C16	0.26
M20	170	6 – 9	16	3	240	25	1 × C20	0.57
M24	210	8 – 12	19	4	270	28	1 × C24	0.92
M27	240	8 – 12	22	4	330	30	1 × C24	1.42
M30	280	8 – 12	24	4	360	35	1 × C30	1.91
M36	330	10 – 15	29	5	420	40	1 × C30	3.21
M42	420	14 – 21	34	7	500	50	2 × C30	5.21
M48	480	16 – 24	38	8	580	54	2 × C30 + 1 × C24	7.90
M56	560	18 – 27	45	9	–	64	4 × C30	13.0

$A = E + G + H + J$, rounded up to nearest 10mm.

E = clear threads after assembly.

H = clamping thickness of fender.

The EC2 anchor is used for installing fenders onto existing concrete or where cast-in anchors are unsuitable. The anchor is usually secured into a drilled hole using special grout capsules. Non-standard sizes and other grout systems are available on request.

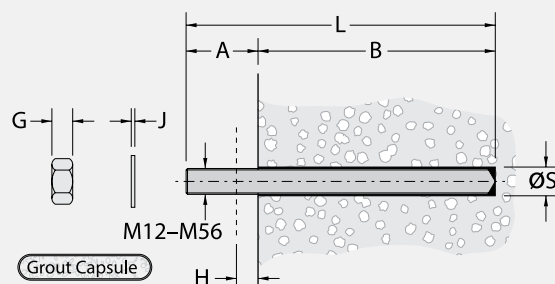

Always follow the manufacturer's instructions when installing EC2 anchors.

[Units: mm, kg]

Fender Fixings

BOLTS, NUTS AND WASHERS

SIZE	THREAD AREA *	WASHERS †				NUTS #			TYPICAL THREAD LENGTHS ‡		THREAD PITCH
	(mm ²)	OD	ID	t	WEIGHT	AF	T	WEIGHT	L≤125	L>125	
M16	157	30	18	3	0.01	24	13	0.04	38	44	2.0
M20	245	37	22	3	0.02	30	16	0.07	46	52	2.5
M24	353	44	26	4	0.03	36	19	0.12	54	60	3.0
M27	459	52	29	4	0.05	41	22	0.23	60	66	3.0
M30	561	56	33	4	0.06	46	24	0.24	66	72	3.5
M36	817	66	39	5	0.09	55	29	0.40	78	84	4.0
M42	1120	78	45	7	0.18	65	34	0.63	90	96	4.5
M48	1470	92	52	8	0.28	75	38	0.90	102	108	5.0
M56	2030	105	62	9	0.40	85	45	1.43	118	124	5.5
M64	2680	115	70	9	0.45	95	51	2.09	134	140	6.0

* Standard bolts given according to DIN933.

[Units: mm, kg]

† Standard washers given according to DIN125. Larger OD washers available on request.

‡ Thread lengths may vary depending on standard. Other lengths available.

Standard nuts given according to DIN934.

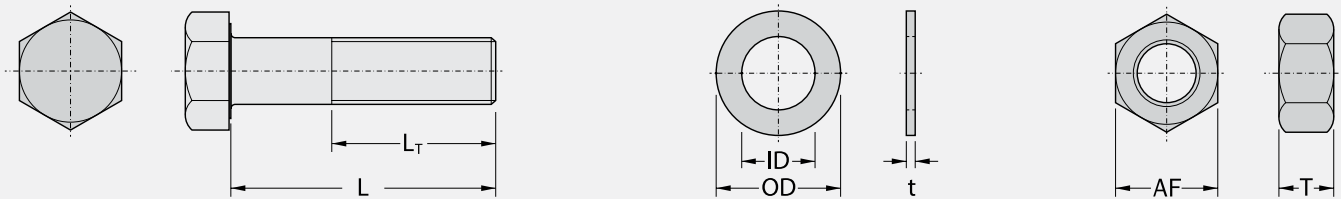

Grades

	ISO 898 GALVANIZED		ISO 356 STAINLESS STEEL *	
Bolt grade	4.6	8.8	A-50 †	A-70 †
Nut grade	4	8	A-50 †	A-70 †
Tensile strength (MPa)	400	800	500	700
0.2% yield stress (MPa)	240	640	210	450

* Refer to Fender Application Design Manual for further details about PREN and galling.

† Size ≤ M39 unless agreed with manufacturer.

‡ Size ≤ M24 unless agreed with manufacturer.

Fenders must be properly fixed to operate correctly. Anchors are supplied to suit new or existing structures, in various strength ratings and with the choice of galvanized or various stainless steels.

DISCLAIMER

Trelleborg AB has made every effort to ensure that the technical specifications and product descriptions in this brochure are correct.

The responsibility or liability for errors and omissions cannot be accepted for any reason whatsoever. Customers are advised to request a detailed specification and certified drawing prior to construction and manufacture. In the interests of improving the quality and performance of our products and systems, we reserve the right to make specification changes without prior notice. All dimensions, material properties and performance values quoted are subject to normal production and testing tolerances.

This brochure supersedes the information provided in all previous editions. If in doubt, please check with Trelleborg Marine and Infrastructure.

© Trelleborg AB, PO Box 153, 231 22
Trelleborg, Sweden.

This brochure is the copyright of Trelleborg AB and may not be reproduced, copied or distributed to third parties without the prior consent of Trelleborg AB in each case.





Trelleborg is a world leader in engineered polymer solutions that seal, damp and protect critical applications in demanding environments. Its innovative solutions accelerate performance for customers in a sustainable way.

WWW.TRELLEBORG.COM/MARINEANDINFRASTRUCTURE



facebook: [TrelleborgMarineandInfrastructure](https://www.facebook.com/TrelleborgMarineandInfrastructure)
twitter: [@TrelleborgMI](https://twitter.com/TrelleborgMI)
[youtube.com/c/TrelleborgMarineInfrastructure](https://www.youtube.com/c/TrelleborgMarineInfrastructure)
[flickr.com/people/marineandinfrastructure](https://www.flickr.com/people/marineandinfrastructure)
[linkedin.com/company/trelleborg-marine-and-infrastructure](https://www.linkedin.com/company/trelleborg-marine-and-infrastructure)
TheSmarterApproachBlog.trelleborg.com