

SCK Cell Fenders



SCK cell fenders have a very long track record and remain popular because of their simplicity, high performance and strength.

They come in a wide range of standard sizes and are interchangeable with many older cell fender types.

FEATURES

- High performance
- Can support large panels
- Strong, well-proven design
- Ideal for low hull pressure systems

APPLICATIONS

- Oil and LNG facilities
- Bulk terminals
- Offshore platforms
- Container berths
- RoRo and cruise terminals
- Multi-user berths

SCK Cell Fenders

DIMENSIONS

	H	ØW	ØB	D	ANCHORS / HEAD BOLTS ^	WEIGHT
SCK 400	400	650	550	24 – 32	4 × M20	75
SCK 500	500	650	550	24 – 32	4 × M24	95
SCK 630	630	840	700	24 – 32	4 × M27	220
SCK 800	800	1050	900	30 – 40	6 × M30	400
SCK 1000	1000	1300	1100	33 – 43	6 × M36	790
SCK 1150	1150	1500	1300	38 – 48	6 × M42	1200
SCK 1250	1250	1650	1450	38 – 48	6 × M42	1500
SCK 1450	1450	1850	1650	43 – 53	6 × M48	2300
SCK 1600	1600	2000	1800	45 – 55	8 × M48	3000
SCK 1700	1700	2100	1900	52 – 62	8 × M56	3700
SCK 2000	2000	2200	2000	50 – 65	8 × M64	5000
SCK 2250	2250	2550	2300	55 – 70	10 × M64	7400
SCK 2500	2500	2950	2700	65 – 80	10 × M64	10700
SCK 3000	3000	3350	3150	70 – 90	12 × M76	18500

^ Fender anchors / head bolts indicated are based on fenders RDP performance using a particular grade of steel. Please contact our local office for precise size, material and type for different grades of fenders pertaining to the project requirements.

[Units: mm, kg]

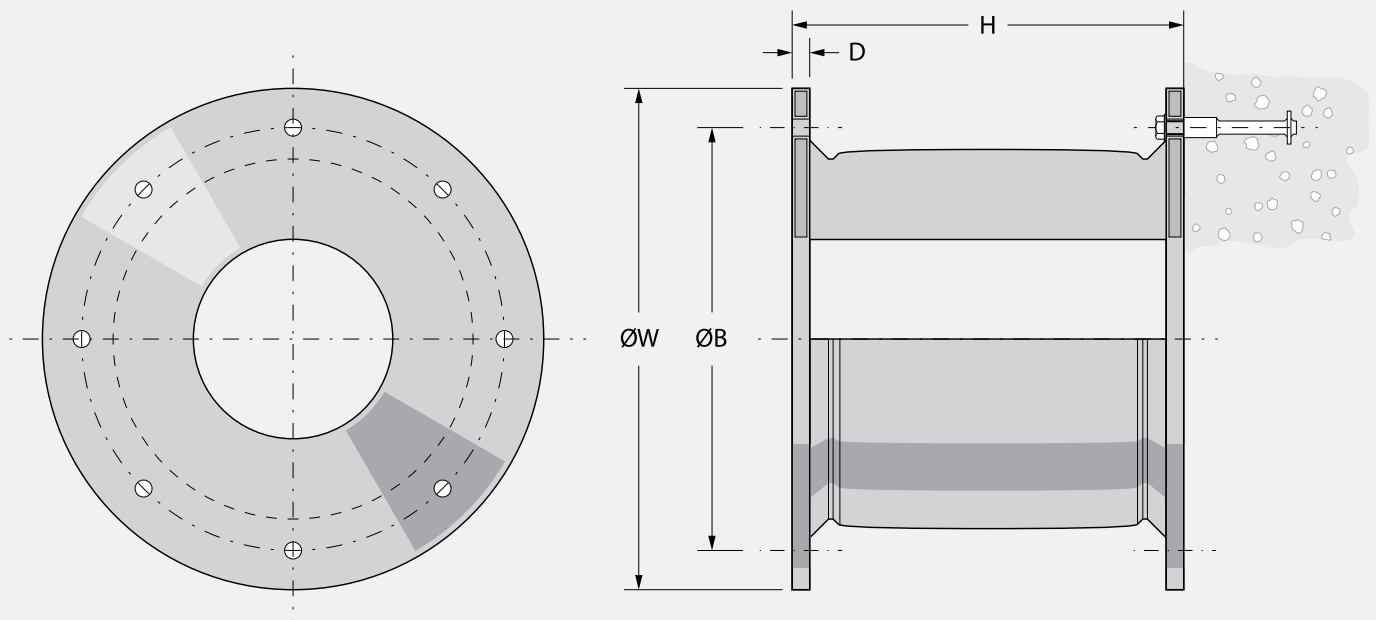

SCK Cell Fenders

PERFORMANCE DATA*

			E 0.9	E 1.0	E 1.1	E 1.2	E 1.3	E 1.4	E 1.5	E 1.6	E 1.7	E 1.8	E 1.9	E 2.0
400	CV	E	9.0	10.0	10.6	11.2	11.8	12.4	13.0	13.6	14.2	14.8	15.4	16.0
		R	50.0	56.0	59.6	63.2	66.8	70.4	74.0	77.4	80.8	84.2	87.6	91.0
	RPD	E _R	10.5	11.7	12.4	13.1	13.8	14.5	15.2	15.9	16.6	17.3	18.0	18.7
		R _R	58.5	65.5	69.7	73.9	78.2	82.4	86.6	90.6	94.5	98.5	102.5	106.5
500	CV	E	17.0	19.0	20.2	21.4	22.6	23.8	25.0	26.0	27.0	28.0	29.0	30.0
		R	79.0	87.0	92.6	98.2	103.8	109.4	115.0	120.4	125.8	131.2	136.6	142.0
	RPD	E _R	19.6	21.9	23.2	24.6	26.0	27.4	28.8	29.9	31.1	32.2	33.4	34.5
		R _R	90.9	100.1	106.5	112.9	119.4	125.8	132.3	138.5	144.7	150.9	157.1	163.3
630	CV	E	34.0	38.0	40.4	42.8	45.2	47.6	50.0	52.4	54.8	57.2	59.6	62.0
		R	124.0	137.0	145.6	154.2	162.8	171.4	180.0	188.8	197.6	206.4	215.2	224.0
	RPD	E _R	38.8	43.3	46.1	48.8	51.5	54.3	57.0	59.7	62.5	65.2	67.9	70.7
		R _R	141.4	156.2	166.0	175.8	185.6	195.4	205.2	215.2	225.3	235.3	245.3	255.4
800	CV	E	67.0	75.0	80.0	85.0	90.0	95.0	100.0	104.8	109.6	114.4	119.2	124.0
		R	190.0	211.0	225.4	239.8	254.2	268.6	283.0	297.4	311.8	326.2	340.6	355.0
	RPD	E _R	76.0	85.1	90.8	96.5	102.2	107.8	113.5	118.9	124.4	129.8	135.3	140.7
		R _R	215.7	239.5	255.8	272.2	288.5	304.9	321.2	337.5	353.9	370.2	386.6	402.9
1000	CV	E	138.0	153.0	162.6	172.2	181.8	191.4	201.0	210.6	220.2	229.8	239.4	249.0
		R	314.0	349.0	370.8	392.6	414.4	436.2	458.0	480.0	502.0	524.0	546.0	568.0
	RPD	E _R	154.6	171.4	182.1	192.9	203.6	214.4	225.1	235.9	246.6	257.4	268.1	278.9
		R _R	351.7	390.9	415.3	439.7	464.1	488.5	513.0	537.6	562.2	586.9	611.5	636.2
1150	CV	E	210.0	233.0	247.6	262.2	276.8	291.4	306.0	320.6	335.2	349.8	364.4	379.0
		R	416.0	462.0	490.8	519.6	548.4	577.2	606.0	634.8	663.6	692.4	721.2	750.0
	RPD	E _R	232.1	257.5	273.6	289.7	305.9	322.0	338.1	354.3	370.4	386.5	402.7	418.8
		R _R	459.7	510.5	542.3	574.2	606.0	637.8	669.6	701.5	733.3	765.1	796.9	828.8
1250	CV	E	269.0	299.0	317.8	336.6	355.4	374.2	393.0	411.6	430.2	448.8	467.4	486.0
		R	491.0	545.0	579.2	613.4	647.6	681.8	716.0	750.2	784.4	818.6	852.8	887.0
	RPD	E _R	295.9	328.9	349.6	370.3	390.9	411.6	432.3	452.8	473.2	493.7	514.1	534.6
		R _R	540.1	599.5	637.1	674.7	712.4	750.0	787.6	825.2	862.8	900.5	938.1	975.7
1450	CV	E	421.0	468.0	497.2	526.4	555.6	584.8	614.0	643.2	672.4	701.6	730.8	760.0
		R	661.0	734.0	781.0	828.0	875.0	922.0	969.0	1013.8	1058.6	1103.4	1148.2	1193.0
	RPD	E _R	458.9	510.1	541.9	573.8	605.6	637.4	669.3	701.1	732.9	764.7	796.6	828.4
		R _R	720.5	800.1	851.3	902.5	953.8	1005.0	1056.2	1105.0	1153.9	1202.7	1251.5	1300.4
1600	CV	E	566.0	629.0	668.2	707.4	746.6	785.8	825.0	864.2	903.4	942.6	981.8	1021.0
		R	805.0	894.0	950.0	1006.0	1062.0	1118.0	1174.0	1229.8	1285.6	1341.4	1397.2	1453.0
	RPD	E _R	616.9	685.6	728.3	771.1	813.8	856.5	899.3	942.0	984.7	1027.4	1070.2	1112.9
		R _R	877.5	974.5	1035.5	1096.5	1157.6	1218.6	1279.7	1340.5	1401.3	1462.1	1522.9	1583.8

* For explanation of CV and RPD, please refer to note on page 19-20.

[Units: kNm, kN]

SCK Cell Fenders

PERFORMANCE DATA*

			E 2.1	E 2.2	E 2.3	E 2.4	E 2.5	E 2.6	E 2.7	E 2.8	E 2.9	E 3.0	E 3.1
400	CV	E	16.4	16.8	17.2	17.6	18.0	18.6	19.2	19.8	20.4	21.0	23.0
		R	93.6	96.2	98.8	101.4	104.0	106.8	109.6	112.4	115.2	118.0	129.0
	RPD	E _R	19.2	19.7	20.1	20.6	21.1	21.8	22.5	23.2	23.9	24.6	26.9
		R _R	109.5	112.6	115.6	118.6	121.7	125.0	128.2	131.5	134.8	138.1	150.9
500	CV	E	31.0	32.0	33.0	34.0	35.0	35.8	36.6	37.4	38.2	39.0	43.0
		R	146.2	150.4	154.6	158.8	163.0	167.2	171.4	175.6	179.8	184.0	203.0
	RPD	E _R	35.7	36.8	38.0	39.1	40.3	41.2	42.1	43.0	43.9	44.9	49.5
		R _R	168.1	173.0	177.8	182.6	187.5	192.3	197.1	201.9	206.8	211.6	233.5
630	CV	E	63.8	65.6	67.4	69.2	71.0	72.8	74.6	76.4	78.2	80.0	88.0
		R	230.6	237.2	243.8	250.4	257.0	263.6	270.2	276.8	283.4	290.0	319.0
	RPD	E _R	72.7	74.8	76.8	78.9	80.9	83.0	85.0	87.1	89.1	91.2	100.3
		R _R	262.9	270.4	277.9	285.5	293.0	300.5	308.0	315.6	323.1	330.6	363.7
800	CV	E	128.0	132.0	136.0	140.0	144.0	147.8	151.6	155.4	159.2	163.0	179.0
		R	365.8	376.6	387.4	398.2	409.0	420.0	431.0	442.0	453.0	464.0	510.0
	RPD	E _R	145.3	149.8	154.4	158.9	163.4	167.8	172.1	176.4	180.7	185.0	203.2
		R _R	415.2	427.4	439.7	452.0	464.2	476.7	489.2	501.7	514.2	526.6	578.9
1000	CV	E	256.4	263.8	271.2	278.6	286.0	293.6	301.2	308.8	316.4	324.0	356.0
		R	585.0	602.0	619.0	636.0	653.0	669.8	686.6	703.4	720.2	737.0	811.0
	RPD	E _R	287.2	295.5	303.7	312.0	320.3	328.8	337.3	345.9	354.4	362.9	398.7
		R _R	655.2	674.2	693.3	712.3	731.4	750.2	769.0	787.8	806.6	825.4	908.3
1150	CV	E	390.4	401.8	413.2	424.6	436.0	447.2	458.4	469.6	480.8	492.0	541.0
		R	772.6	795.2	817.8	840.4	863.0	885.6	908.2	930.8	953.4	976.0	1073.0
	RPD	E _R	431.4	444.0	456.6	469.2	481.8	494.2	506.5	518.9	531.3	543.7	597.8
		R _R	853.7	878.7	903.7	928.6	953.6	978.6	1003.6	1028.5	1053.5	1078.5	1185.7
1250	CV	E	500.6	515.2	529.8	544.4	559.0	573.8	588.6	603.4	618.2	633.0	696.0
		R	913.6	940.2	966.8	993.4	1020.0	1046.6	1073.2	1099.8	1126.4	1153.0	1269.0
	RPD	E _R	550.7	566.7	582.8	598.8	614.9	631.2	647.5	663.7	680.0	696.3	765.6
		R _R	1005.0	1034.2	1063.5	1092.7	1122.0	1151.3	1180.5	1209.8	1239.0	1268.3	1395.9
1450	CV	E	782.8	805.6	828.4	851.2	874.0	896.8	919.6	942.4	965.2	988.0	1086.0
		R	1228.8	1264.6	1300.4	1336.2	1372.0	1407.8	1443.6	1479.4	1515.2	1551.0	1707.0
	RPD	E _R	853.3	878.1	903.0	927.8	952.7	977.5	1002.4	1027.2	1052.1	1076.9	1183.7
		R _R	1339.4	1378.4	1417.4	1456.5	1495.5	1534.5	1573.5	1612.5	1651.6	1690.6	1860.6
1600	CV	E	1051.6	1082.2	1112.8	1143.4	1174.0	1204.6	1235.2	1265.8	1296.4	1327.0	1460.0
		R	1496.6	1540.2	1583.8	1627.4	1671.0	1714.6	1758.2	1801.8	1845.4	1889.0	2078.0
	RPD	E _R	1146.2	1179.6	1213.0	1246.3	1279.7	1313.0	1346.4	1379.7	1413.1	1446.4	1591.4
		R _R	1631.3	1678.8	1726.3	1773.9	1821.4	1868.9	1916.4	1964.0	2011.5	2059.0	2265.0

* For explanation of CV and RPD, please refer to note on page 19-20.

[Units: kNm, kN]

SCK Cell Fenders

PERFORMANCE DATA*

			E 0.9	E 1.0	E 1.1	E 1.2	E 1.3	E 1.4	E 1.5	E 1.6	E 1.7	E 1.8	E 1.9	E 2.0
1700	CV	E	678.0	753.0	800.2	847.4	894.6	941.8	989.0	1036.2	1083.4	1130.6	1177.8	1225.0
		R	908.0	1009.0	1072.2	1135.4	1198.6	1261.8	1325.0	1388.2	1451.4	1514.6	1577.8	1641.0
	RPD	E _R	739.0	820.8	872.2	923.7	975.1	1026.6	1078.0	1129.5	1180.9	1232.4	1283.8	1335.3
		R _R	989.7	1099.8	1168.7	1237.6	1306.5	1375.4	1444.3	1513.1	1582.0	1650.9	1719.8	1788.7
2000	CV	E	1104.0	1227.0	1303.6	1380.2	1456.8	1533.4	1610.0	1686.8	1763.6	1840.4	1917.2	1994.0
		R	1258.0	1397.0	1484.2	1571.4	1658.6	1745.8	1833.0	1920.0	2007.0	2094.0	2181.0	2268.0
	RPD	E _R	1186.8	1319.0	1401.4	1483.7	1566.1	1648.4	1730.8	1813.3	1895.9	1978.4	2061.0	2143.6
		R _R	1352.4	1501.8	1595.5	1689.3	1783.0	1876.7	1970.5	2064.0	2157.5	2251.1	2344.6	2438.1
2250	CV	E	1854.0	2060.0	2169.2	2278.4	2387.6	2496.8	2606.0	2715.0	2824.0	2933.0	3042.0	3151.0
		R	1876.0	2085.0	2195.4	2305.8	2416.2	2526.6	2637.0	2747.4	2857.8	2968.2	3078.6	3189.0
	RPD	E _R	1983.8	2204.2	2321.0	2437.9	2554.7	2671.6	2788.4	2905.1	3021.7	3138.3	3254.9	3371.6
		R _R	2007.3	2231.0	2349.1	2467.2	2585.3	2703.5	2821.6	2939.7	3057.8	3176.0	3294.1	3412.2
2500	CV	E	2544.0	2826.0	2975.8	3125.6	3275.4	3425.2	3575.0	3724.6	3874.2	4023.8	4173.4	4323.0
		R	2317.0	2574.0	2710.4	2846.8	2983.2	3119.6	3256.0	3392.2	3528.4	3664.6	3800.8	3937.0
	RPD	E _R	2696.6	2995.6	3154.3	3313.1	3471.9	3630.7	3789.5	3948.1	4106.7	4265.2	4423.8	4582.4
		R _R	2456.0	2728.4	2873.0	3017.6	3162.2	3306.8	3451.4	3595.7	3740.1	3884.5	4028.8	4173.2
3000	CV	E	3795.0	4217.0	4452.4	4687.8	4923.2	5158.6	5394.0	5629.4	5864.8	6100.2	6335.6	6571.0
		R	3310.0	3678.0	3879.0	4080.0	4281.0	4482.0	4683.0	4884.0	5085.0	5286.0	5487.0	5688.0
	RPD	E _R	3984.8	4427.9	4675.0	4922.2	5169.4	5416.5	5663.7	5910.9	6158.0	6405.2	6652.4	6899.6
		R _R	3475.5	3861.9	4073.0	4284.0	4495.1	4706.1	4917.2	5128.2	5339.3	5550.3	5761.4	5972.4

[Units: kNm, kN]

*Note:

- CV: performance data at slow speed constant velocity (2-8 cm/min) compression at 23 ±5°C temperature and 0° compression angle.
- RPD: Rated performance data, in accordance with PIANC with initial high speed berthing velocity 0.15 m/s.
 $RPD = CV \text{ (performance)} \times VF \text{ (velocity factor for Natural and Synthetic rubber blend)} \times TF \text{ (temperature factor)} \times AF \text{ (angle factor)}$.
 RPD is reported at 23 ±5°C temperature and 0° compression angle, therefore $TF = 1$, $AF = 1$.

SCK Cell Fenders

PERFORMANCE DATA*

			E 2.1	E 2.2	E 2.3	E 2.4	E 2.5	E 2.6	E 2.7	E 2.8	E 2.9	E 3.0	E 3.1
1700	CV	E	1261.6	1298.2	1334.8	1371.4	1408.0	1444.8	1481.6	1518.4	1555.2	1592.0	1751.0
		R	1690.0	1739.0	1788.0	1837.0	1886.0	1935.2	1984.4	2033.6	2082.8	2132.0	2345.0
	RPD	E _R	1375.1	1415.0	1454.9	1494.8	1534.7	1574.8	1614.9	1655.1	1695.2	1735.3	1908.6
		R _R	1842.1	1895.5	1948.9	2002.3	2055.7	2109.4	2163.0	2216.6	2270.3	2323.9	2556.1
2000	CV	E	2053.8	2113.6	2173.4	2233.2	2293.0	2352.8	2412.6	2472.4	2532.2	2592.0	2851.0
		R	2335.4	2402.8	2470.2	2537.6	2605.0	2672.4	2739.8	2807.2	2874.6	2942.0	3236.0
	RPD	E _R	2207.8	2272.1	2336.4	2400.7	2465.0	2529.3	2593.5	2657.8	2722.1	2786.4	3064.8
		R _R	2510.6	2583.0	2655.5	2727.9	2800.4	2872.8	2945.3	3017.7	3090.2	3162.7	3478.7
2250	CV	E	3245.6	3340.2	3434.8	3529.4	3624.0	3718.4	3812.8	3907.2	4001.6	4096.0	4506.0
		R	3284.8	3380.6	3476.4	3572.2	3668.0	3763.6	3859.2	3954.8	4050.4	4146.0	4561.0
	RPD	E _R	3472.8	3574.0	3675.2	3776.5	3877.7	3978.7	4079.7	4180.7	4281.7	4382.7	4821.4
		R _R	3514.7	3617.2	3719.7	3822.3	3924.8	4027.1	4129.3	4231.6	4333.9	4436.2	4880.3
2500	CV	E	4452.6	4582.2	4711.8	4841.4	4971.0	5100.6	5230.2	5359.8	5489.4	5619.0	6181.0
		R	4055.2	4173.4	4291.6	4409.8	4528.0	4646.2	4764.4	4882.6	5000.8	5119.0	5631.0
	RPD	E _R	4719.8	4857.1	4994.5	5131.9	5269.3	5406.6	5544.0	5681.4	5818.8	5956.1	6551.9
		R _R	4298.5	4423.8	4549.1	4674.4	4799.7	4925.0	5050.3	5175.6	5300.8	5426.1	5968.9
3000	CV	E	6761.8	6952.6	7143.4	7334.2	7525.0	7715.8	7906.6	8097.4	8288.2	8479.0	9327.0
		R	5855.6	6023.2	6190.8	6358.4	6526.0	6693.4	6860.8	7028.2	7195.6	7363.0	8099.0
	RPD	E _R	7099.9	7300.2	7500.6	7700.9	7901.3	8101.6	8301.9	8502.3	8702.6	8903.0	9793.4
		R _R	6148.4	6324.4	6500.3	6676.3	6852.3	7028.1	7203.8	7379.6	7555.4	7731.2	8504.0

[Units: kNm, kN]

- For other initial berthing velocities, temperature and berthing angle, VF/ TF/ AF should be calculated separately and apply on CV performance to come to the final performance.
- If fenders are tested in decreasing velocity (DV) mode at initial velocity 0.15 m/s, 0° compression angle and 23 ±5°C testing temperature, RPD = DV (performance).
- Fender performance is subject to ±10% manufacturing tolerance (+10% for reaction force and -10% for energy).
- CV performance is based on a rubber compound blend of natural and synthetic rubber.

SCK Cell Fenders

INTERMEDIATE DEFLECTIONS

D_i (%)	0	5	10	15	20	25	30	35	40	45	50	52.5	55
E_i (%)	0	2	7	16	26	38	50	61	72	83	94	100	106
R_i (%)	0	32	60	81	94	99	99	96	92	92	96	100	106

Nominal rated deflection may vary at RPD. Refer to the Performance Tolerances table in the Fender Application Design Manual.

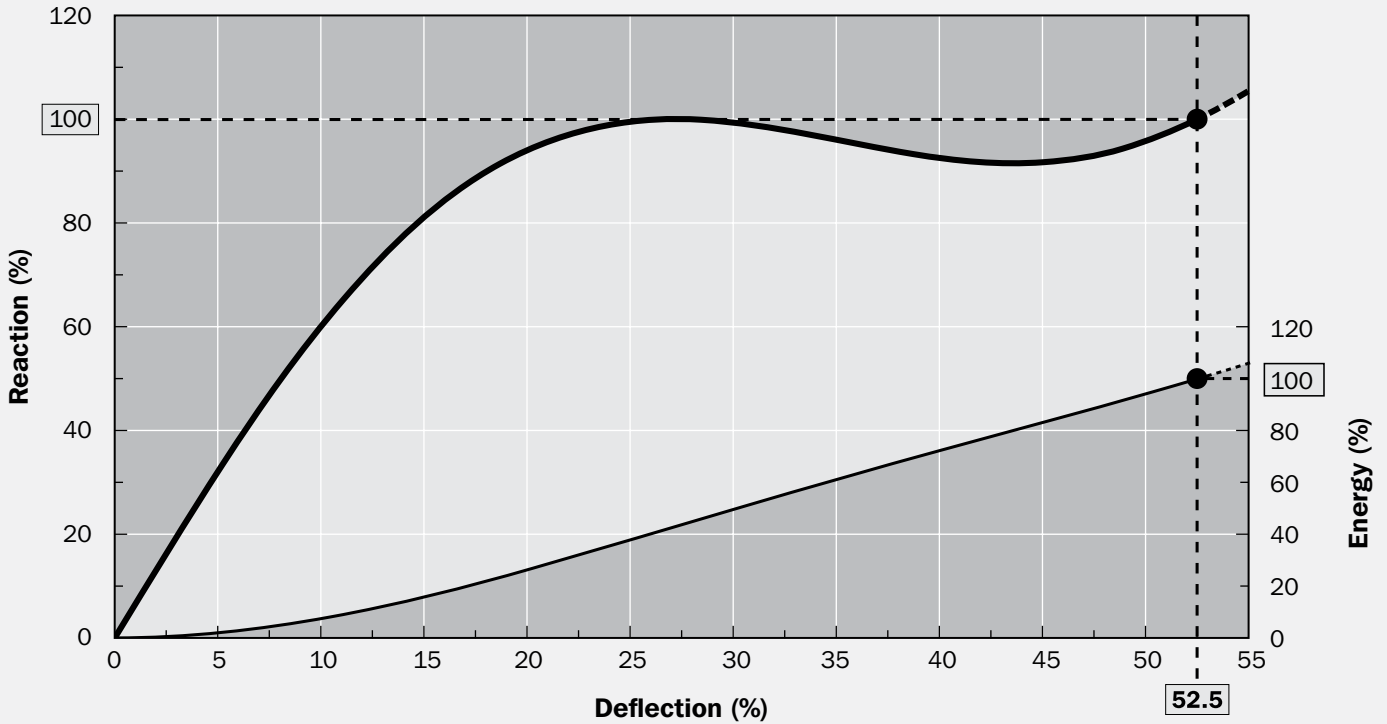

Generic curve shown. Actual curve geometry may vary depending on grade, temperature, velocity and angle.

ANGLE FACTOR (AF) TABLE

ANGLE (°)	ENERGY FACTOR	REACTION FACTOR
0	1.000	1.000
3	0.977	1.000
5	0.951	1.000
8	0.909	1.000
10	0.883	1.000
15	0.810	1.000
20	0.652	1.000

SCK Cell Fenders

VELOCITY FACTOR (VF) TABLE

COMPRESSION TIME (SECONDS)	BLEND OF NATURAL AND SYNTHETIC RUBBER (CATALOG COMPOUND)	100% NATURAL RUBBER	100% SYNTHETIC RUBBER (SBR)
	VF	VF	VF
1	1.20	1.14	1.31
2	1.16	1.10	1.25
3	1.14	1.09	1.22
4	1.13	1.07	1.20
5	1.11	1.06	1.19
6	1.10	1.06	1.17
7	1.09	1.05	1.16
8	1.09	1.04	1.15
9	1.08	1.04	1.14
10	1.07	1.03	1.14
11	1.07	1.03	1.13
12	1.06	1.02	1.12
13	1.06	1.02	1.12
14	1.05	1.02	1.11
15	1.05	1.01	1.11
16	1.05	1.01	1.10
17	1.04	1.01	1.10
18	1.04	1.01	1.09
19	1.04	1.00	1.09
20	1.03	1.00	1.08

Compression time needs to be calculated using the following formula: $t = d/(f \cdot Vd)$

Where:

t = compression time (seconds)*

d = rated deflection (mm)

Vd = initial berthing velocity (mm/s)

f = 0.74 deceleration factor (Peak reaction force occurs at between 30% - 40% deflection, where there has been a deceleration due to energy absorption. f represents the factor associated with deceleration.)

* Applicable for both partial deflection and rated deflection.

TEMPERATURE FACTOR (TF) TABLE

TEMPERATURE (°C)	BLEND OF NATURAL AND SYNTHETIC RUBBER (CATALOG COMPOUND)	100% NATURAL RUBBER	100% SYNTHETIC RUBBER (SBR)
	TF	TF	TF
+50	0.916	0.914	0.918
+40	0.947	0.946	0.948
+30	0.978	0.978	0.979
+23	1.000	1.000	1.000
+10	1.030	1.025	1.038
+0	1.075	1.053	1.108
-10	1.130	1.080	1.206
-20	1.249	1.142	1.410
-30	1.540	1.315	1.877

SCK Cell Fenders

CLEARANCES

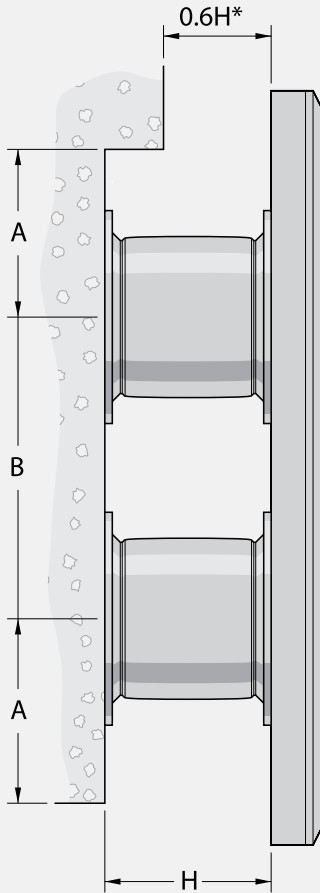

*Does not allow for bow flares

There must be enough space around and between the Cell fenders and the steel panel to allow them to deflect without interference.

Distances given in the above diagram are for guidance. If in doubt, please ask.

SCK (H)	EDGE (A)	CENTRES (B)
400	480	700
500	510	700
630	600	880
800	700	1120
1000	850	1500
1150	990	1730
1250	1060	1870
1450	1200	2180
1600	1270	2400
1700	1470	2550
2000	1560	2880
2250	1710	3360
2500	1910	3730
3000	2240	4500

[Units: mm]

WEIGHT SUPPORT

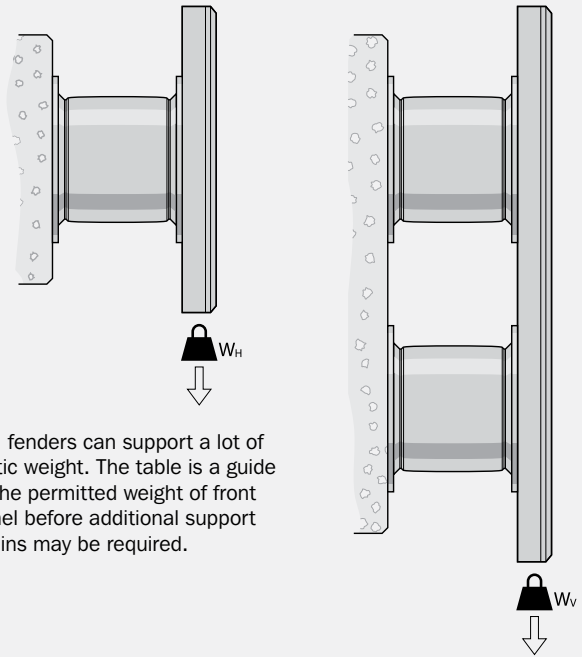

Cell fenders can support a lot of static weight. The table is a guide to the permitted weight of front panel before additional support chains may be required.

SCK	SINGLE OR MULTIPLE HORIZONTAL (n ≥ 1)	MULTIPLE VERTICAL (n ≥ 2)	H
E1	$W_H \leq n \times 1.0 \times W$	$W_V \leq n \times 1.25 \times W$	≤ 800
E2	$W_H \leq n \times 1.3 \times W$	$W_V \leq n \times 1.75 \times W$	
E3	$W_H \leq n \times 1.5 \times W$	$W_V \leq n \times 2.25 \times W$	
E1	$W_H \leq n \times 11 \times W^{0.6}$	$W_V \leq n \times 13.75 \times W^{0.6}$	≥ 1000
E2	$W_H \leq n \times 19 \times W^{0.6}$	$W_V \leq n \times 23.75 \times W^{0.6}$	
E2	$W_H \leq n \times 25 \times W^{0.6}$	$W_V \leq n \times 31.25 \times W^{0.6}$	

n = number of Cell fenders.

W = SCK weight

W_H = panel weight (single or multi-horizontal)

W_V = panel weight (single or multi-vertical)

Interpolate for other grades

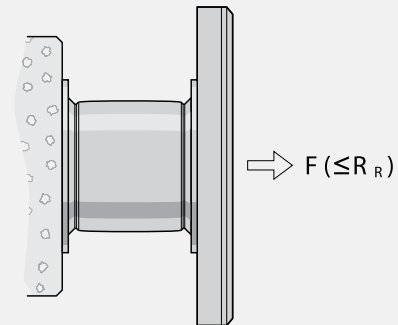

If the tensile load exceeds the rated reaction then tension chains may be required. Please ask for advice on the design of tension chains.

- 1. SINGAPORE
- 2. DJIBOUTI
- 3. ITALY
- 4. SINGAPORE
- 5. VIETNAM
- 6. USA
- 7. NETHERLANDS MAASVLAKTE
- 8. VENEZUELA

