

Water Infrastructure

**TAME THE RAW, DESTRUCTIVE POWER OF WATER.
BUILD RESILIENT WATER INFRASTRUCTURE
WITH OUR INNOVATIVE SOLUTIONS.**



Smarter Polymer and Water Infrastructure Solutions

The growing global population, rise of emerging economies and impact of increasingly unpredictable climate events, place even greater pressure on our environment. The world we live and work in is constantly changing, and civil engineered infrastructure must be more reliable and robust than ever to keep up.

With its extensive experience designing polymer sealing systems and damping solutions, Trelleborg Marine and Infrastructure provides cutting-edge products that can withstand extreme environmental challenges.

In addition to our unmatched global reach, strong regional presence and cross-industry expertise, we have in-house end-to-end solution capabilities, helping us deliver greater efficiency and value across our projects.



WORLD-CLASS WATER INFRASTRUCTURE SOLUTIONS

Trelleborg's expertise in water infrastructure solutions is second to none. Our expertise in design, combined with our years of experience, puts us at the forefront of the industry and enables us to solve water infrastructure problems.

Across the globe, governments, engineering companies, consultants and contractors entrust us with planning, designing and implementing water infrastructure projects. As the industry leader in sealing, damping and protecting wet infrastructure, our products and services are available worldwide.

To ensure that our water infrastructure solutions are fit for purpose, we involve ourselves throughout the entire project life cycle – from product scoping to design, evaluation, testing, installation and maintenance.

Using our unique production technologies and polymer engineering expertise, we deliver water infrastructure solutions and products that can meet all operational challenges – no matter how complex. Essentially, we engineer all of our designs to meet the unique and critical requirements of every project we work on.

With all of these factors combined, our water infrastructure solutions are capable of effectively safeguarding the most critical structures – from storm surge barriers and sluices, to dry docks and lock systems. Our team of highly experienced engineers will work with you to design a bespoke sealing system for your application, and will also inspect and replace sealing systems if necessary.

Contents

CHAPTERS

Smarter Polymer and Water Infrastructure Solutions	2
Sustainability by Design	4
Guaranteed Functionality	5
Customizable Seals and Market Applications	6
Unparalleled Protection Against the Power of Water	8



Sustainability by Design

A CONSULTATIVE APPROACH

From the outset of a project, we work closely with relevant authorities, engineering companies, consultants and contractors. Taking this approach makes it possible for us to design a water infrastructure solution that is efficient and highly reliable.

By involving ourselves extensively in the entire project life cycle, we gain a comprehensive understanding of structures and their performance in the natural environment over time. At every stage of the process, we will work closely with you to evaluate your needs and address them with specialized water infrastructure solutions that you can rely on. With decades of industry experience and a consultative approach, we tailor our solutions to meet your individual requirements.

EXPERT DESIGN

Having worked on a multitude of water infrastructure projects across the globe, Trelleborg's seals protect many areas that have high sea levels and are prone to flooding. It's the high-quality design of our seals that ensures the protection of these areas.

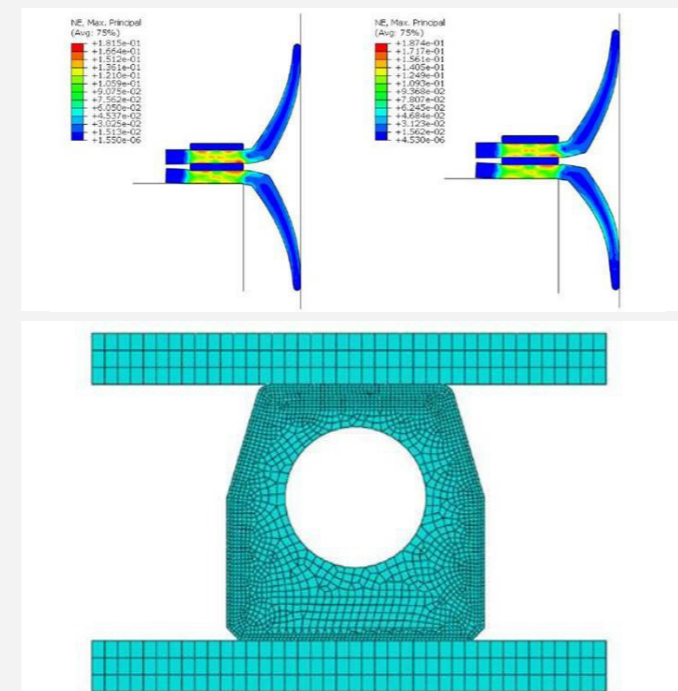

Guaranteed Functionality

Our quality engineering ensures that the project will perform as intended throughout its life cycle, unaffected by the powerful forces of water.

QUALITY-TESTED MATERIALS

Our rubber sealing systems are subject to rigorous testing procedures to ensure that they are fit for purpose for every project. Rubber compounds undergo ozone, UV and temperature, aging, oil and high wear and tear testing to determine the future behaviors of rubber. Furthermore, Trelleborg's products are third-party verified, certifying their quality and performance over time.

INSPECTION, CONSULTANCY AND REPAIR

Trelleborg offers a range of inspections throughout the entire life cycle of a project. These include visual inspections and leakage testing to assess a sealing system's condition. Our highly skilled and certified technicians will carry out any necessary repairs.

ENGINEERING SUSTAINABILITY THROUGH PREMIUM PRODUCT DESIGN

Research, product development and innovation are key aspects of the UN's Sustainable Development Goals 9: Industry, Innovation and Infrastructure and 11: Sustainable Cities and Communities.

In order to achieve these goals, smarter products must be designed to meet the demands of climate change. Integrating sustainability into our water infrastructure solutions is therefore a key priority for us. With this in mind, our team of engineers strive to design innovative, high-quality products that protect today's infrastructure by enhancing its strength and resilience.



Trelleborg's expert design ensures our products outlive the infrastructure they protect.

Customizable Seals and Market Applications

Trelleborg is your partner of choice for customized water infrastructure solutions. Discover our range of market-leading products.

CUSTOMIZABLE SEALS

COMPRESSION SEALS

Our Compression Seals effectively seal expansion joints. The seals create sealing pressure by means of the rubber's reaction due to compressive deformation of the rubber profile. The elastomeric element of the seal is also highly resistant to deterioration from exposure to weather, sunlight, oils and impact.

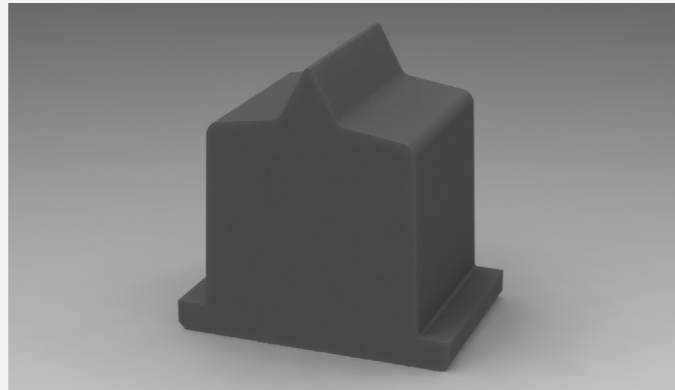

MEMBRANE SEALS

We offer a wide range of Membrane Seals for different applications, such as Omega Joints and Waterstops that secure a gap by fixing the seal on both sides of an opening. Typical Membrane Seals include our standard Omega Seals and Omega WS Seals.

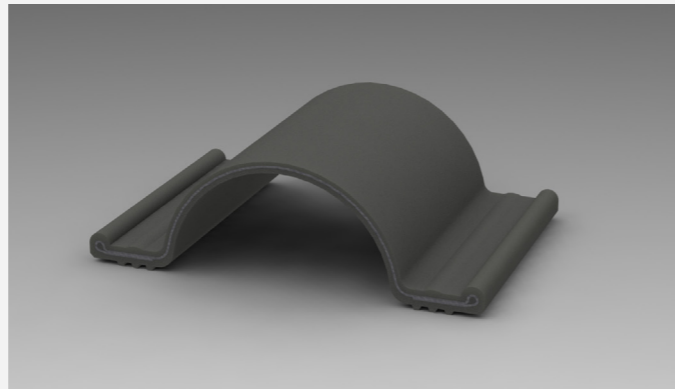

INFLATABLE SEALS

Our Inflatable Seals are designed to seal a gap after being inflated, and are usually used to seal curved edges and special projects. The seal is flat-shaped, with a rubber flange to facilitate installation. During inflation, the flat seal expands and becomes thicker, while the sides deform into a circular shape. The seal is inflated by air or water and is also provided with ridges on the upper and lower contact areas to improve sealing capacity.

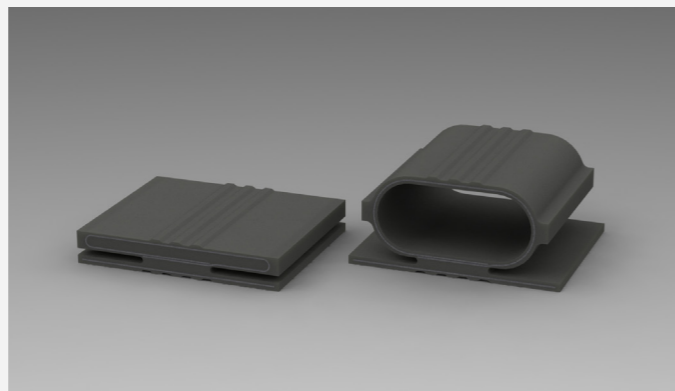

SELF-ACTIVATING SEALS

Our Self-activating Seals act as a girder crossing a gap, and are suitable for a wide range of applications. Trelleborg has designed many bespoke Self-activating Seals for various water sealing projects across the globe.

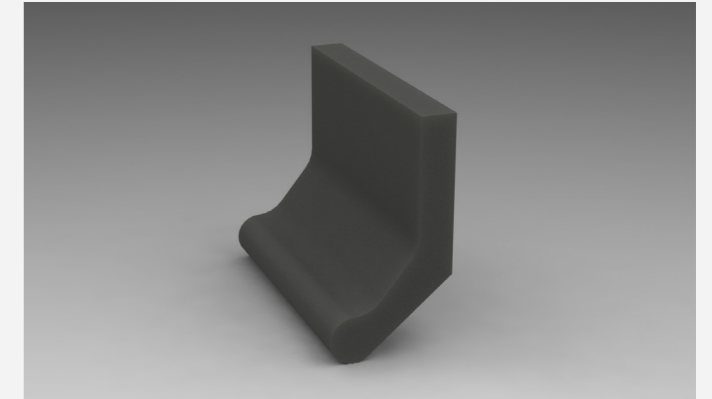

MARKET APPLICATIONS

WATER HYDRAULIC SEALS

Our custom-made Omega Protection Seals and Gina Gaskets are commonly used to seal flood protection applications such as sluices and hydro dams. These seals are primarily designed to prevent water ingress.



DRY DOCK SEALS

Our Dry Dock Seals ensure a leak-free dry dock for optimal ship maintenance, eliminating the need for multiple auxiliary pumps and reducing the associated environmental impact.



Unparalleled Protection Against the Power of Water

Trelleborg's tried-and-tested sealing systems are already delivering exceptional performance in high-profile projects worldwide.



SEALING THE TERNEUZEN SLUICE

The Terneuzen lock in the Netherlands is a new sluice that is one of the largest locks in the world. It is located in Terneuzen at the entrance of the Ghent-Terneuzen canal that connects the inland port of Ghent, Belgium.

Trelleborg supplied bespoke seals for the sluice's concrete bottom floor grids, which are caissons with hole patterns. We sealed clusters of holes with soft, natural rubber that absorbs the irregularity of the concrete and withstands water forces over a lifetime.

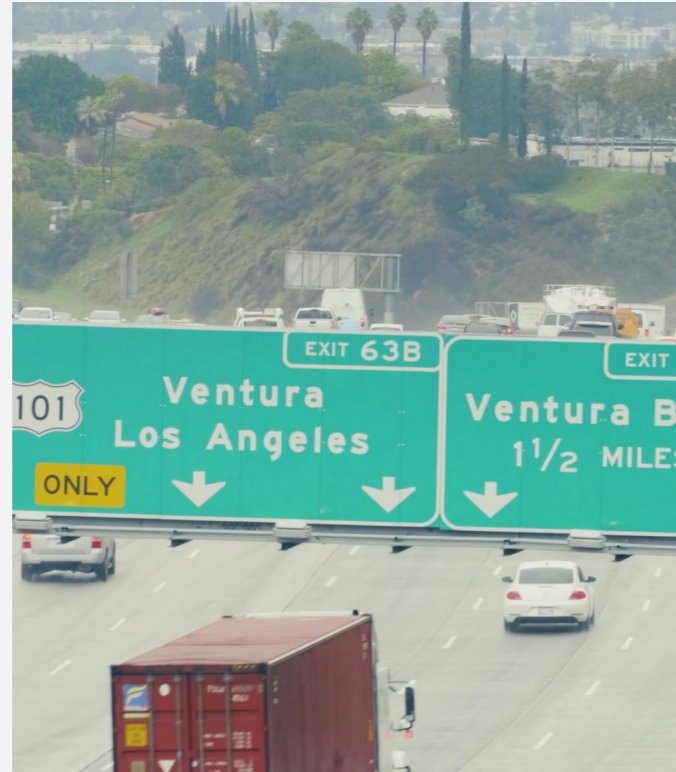

KEEPING CALIFORNIA MOVING

The city of Los Angeles boasts an extensive road system, and maintaining this vital transport link as a whole was a key priority for the Department of Transport for California.

Trelleborg's sealing systems are used throughout Los Angeles' storm drains to prevent water – including excessive rainfall or swell – from entering the city's road infrastructure.

Trelleborg even designs and supplies sealing systems for the Department of Transport in the state of California exclusively.



CONTROLLING KOREA'S RISING RIVERS

The main flood threat in South Korea is from its rivers. To manage the flow of the Nakdong River – the longest river in South Korea – Trelleborg built the 300-meter-long Nakdong storm surge barrier to prevent flooding.

Trelleborg supplied a range of sealing systems to this storm surge project. Self-activating Seals were used due to their inherent flexibility, and Compression Seals were used to provide a comprehensive seal to the expansion joints.

DISCLAIMER

Trelleborg AB has made every effort to ensure that the technical specifications and product descriptions in this brochure are correct.

The responsibility or liability for errors and omissions cannot be accepted for any reason whatsoever. Customers are advised to request a detailed specification and certified drawing prior to construction and manufacture. In the interests of improving the quality and performance of our products and systems, we reserve the right to make specification changes without prior notice. All dimensions, material properties and performance values quoted are subject to normal production and testing tolerances. This brochure supersedes the information provided in all previous editions.

If in doubt, please check with Trelleborg Marine and Infrastructure.

© **Trelleborg AG, PO Box 153, 231 22 Trelleborg, Sweden.**

This brochure is the copyright of Trelleborg AB and may not be reproduced, copied or distributed to third parties without the prior consent of Trelleborg AB in each case.





Trelleborg is a world leader in engineered polymer solutions that seal, damp and protect critical applications in demanding environments. Its innovative solutions accelerate performance for customers in a sustainable way.

WWW.TRELLEBORG.COM/MARINEANDINFRASTRUCTURE



Facebook: [TrelleborgMarineandInfrastructure](https://www.facebook.com/TrelleborgMarineandInfrastructure)

Twitter: [@TrelleborgMI](https://twitter.com/TrelleborgMI)

YouTube: youtube.com/c/trelleborgmarineinfrastructure

LinkedIn: linkedin.com/company/trelleborg-marine-and-infrastructure

Blog: thesmarterapproachblog.trelleborg.com

Trelleborg Marine and Infrastructure

Email: marine_infra@trelleborg.com

2022